

# *Guide to ACTgen Macros*

R1-2003

---

## **Actel Corporation, Sunnyvale, CA 94086**

© 2003 Actel Corporation. All rights reserved.

Part Number: 5029108-8

Release: January 2003

No part of this document may be copied or reproduced in any form or by any means without prior written consent of Actel.

Actel makes no warranties with respect to this documentation and disclaims any implied warranties of merchantability or fitness for a particular purpose.

Information in this document is subject to change without notice. Actel assumes no responsibility for any errors that may appear in this document.

This document contains confidential proprietary information that is not to be disclosed to any unauthorized person without prior written consent of Actel Corporation.

### Trademarks

Actel and the Actel logotype are registered trademarks of Actel Corporation.

Acrobat Reader is a trademark of Adobe Systems, Inc.

Windows is a registered trademark of Microsoft in the U.S. and other countries.

All other products or brand names mentioned are trademarks or registered trademarks of their respective holders.

---

# Table of Contents

<b>Introduction</b> . . . . .	7
Document Conventions . . . . .	7
Symbols . . . . .	8
Your Comments . . . . .	8
Actel Manuals . . . . .	8
Online Help . . . . .	9
<b>Generating Macros Using ACTgen</b> . . . . .	11
ACTgen Features . . . . .	11
ACTgen Main Window . . . . .	12
Generating New Macros . . . . .	13
Modifying Existing Macros . . . . .	15
Fan-in Control Tool . . . . .	17
Generating a Macro Report . . . . .	18
Preferences . . . . .	19
PortMapping Dialog . . . . .	22
Calling ACTgen in Batchmode . . . . .	23
<b>Arithmetic Macros</b> . . . . .	25
Adder . . . . .	26
Array Adder . . . . .	29
Subtractor . . . . .	32
Adder/Subtractor . . . . .	34
Accumulator . . . . .	36
Incrementer . . . . .	39
Decrementer . . . . .	41
Incrementer/Decrementer . . . . .	43
Constant Multiplier . . . . .	45
Multiplier . . . . .	48
Advanced Options . . . . .	52
<b>Comparators</b> . . . . .	55
Magnitude/Equality Comparator . . . . .	56

---

*Table of Contents*

Constant Decoder . . . . . 59

Converters. . . . . 61

    Gray Counter . . . . . 62

    Binary to Gray / Gray to Binary . . . . . 64

Counters. . . . . 65

    Binary Counter . . . . . 66

Decoder . . . . . 72

    Decoder . . . . . 73

IOs . . . . . 75

    Input Buffers . . . . . 76

    Output Buffers . . . . . 78

    Bi-Directional Buffers . . . . . 80

    Tri-State Buffers . . . . . 83

    Global Buffers . . . . . 85

    PECL Global Buffers . . . . . 87

    PerPin FIFO . . . . . 89

    Dual Data Rate Register . . . . . 92

    Dual Data Rate FIFO . . . . . 94

Logic . . . . . 96

    Logic (AND) . . . . . 97

    Logic (OR) . . . . . 98

    Logic (XOR) . . . . . 99

Multiplexer . . . . . 100

    Multiplexer . . . . . 101

Minicores . . . . . 103

    FIR Filter . . . . . 104

    CRC Minicore . . . . . 109

PLLs. . . . . 112

PLL for ProASICPLUS . . . . .	113
Axcelerator PLL . . . . .	115
Register (Storage Elements) . . . . .	117
Storage Register . . . . .	118
Shift Register . . . . .	121
Barrel Shifter . . . . .	124
Storage Latch . . . . .	127
Memory Macros for	
Non-Axcelerator Families . . . . .	130
Synchronous/Asynchronous Dual Port RAM . . . . .	131
Register File . . . . .	138
Synchronous Dual Port FIFO without Flags . . . . .	142
Synchronous Dual Port FIFO with Flags . . . . .	146
FIFO Flag Controller (No RAM) . . . . .	154
Memory Macros for Axcelerator. . . . .	158
Axcelerator RAM . . . . .	159
Axcelerator FIFO . . . . .	163
PerPin FIFO . . . . .	167
Memory Macros for ProASIC . . . . .	168
Synchronous/Asynchronous Dual Port RAM for ProASIC . . . . .	169
Register File for ProASIC . . . . .	171
Synchronous/Asynchronous Dual Port FIFO for ProASIC . . . . .	174
FIFO Using Distributed Memory for ProASIC . . . . .	177
Memory in ProASIC . . . . .	180
Embedded Memory. . . . .	180
Distributed Memory . . . . .	186
Timing for Distrubuted Memories . . . . .	192
Using Multiple Memories in a Design . . . . .	196
Product Support . . . . .	205

---

*Table of Contents*

Actel U.S. Toll-Free Line . . . . . 205  
Customer Service . . . . . 205  
Actel Customer Technical Support Center . . . . . 205  
Guru Automated Technical Support . . . . . 206  
Web Site . . . . . 206  
Contacting the Customer Technical Support Center . . . . . 206  
Worldwide Sales Offices . . . . . 208

---

# Introduction

This Guide provides descriptions of macros that you can generate using the Actel ACTgen Macro Builder Software. For more information about instantiating macros, refer to the *Getting Started User's Guide* and the *Actel HDL Coding Style Guide*.

The Actel ACTgen Macro Builder generates a large variety of commonly used functions. You can generate structural netlists in EDIF, VHDL, and Verilog. Furthermore, you can generate VHDL and Verilog behavioral models for most parameterized functions (the behavioral models may be used in a simulation environment).

Actel's parameterized macros:

- Reduce the development time of complex functions.
- Offer a large set of implementations for each type of function.
- Offer a wide range of bit widths that provides a quick change of design definitions.

## Document Conventions

The following table describes the conventions that are used throughout this manual.

*Table 1. Functional Description of Table Nomenclature*

<b>Symbol</b>	<b>Definition</b>
X	Don't care
1	Logical 1 or high
0	Logical 0 or low
↑	Rising edge
↓	Falling edge
$Q_n$	Value of the signal Q before the active edge of the clock
$Q_{n+1}$	Value of the signal Q after the active edge of the clock

*Table 1. Functional Description of Table Nomenclature (Continued)*

<b>Symbol</b>	<b>Definition</b>
$Q_n$ [width-1 : 0]	$Q_n$ is a width-bit bus
$Q_n$ [width-1	Width-1 bit of $Q_n$
m, n	Binary pattern with width of function

## Symbols

Each macro symbol shows the input and output ports. Busses are highlighted with a bold line; scalar signals with a thin line. The actual symbols generated by ACTgen could look slightly different, depending on the particular CAE tool used. Some ports shown could be optional, as described in the port description tables. Default polarities are shown on the symbols.

## Your Comments

Actel Corporation strives to produce the highest quality online help and printed documentation. We want to help you learn about our products, so you can get your work done quickly. We welcome your feedback about this guide and our online help. Please send your comments to **documentation@actel.com**.

## Actel Manuals

Designer and Libero include printed and online manuals. The online manuals are in PDF format and available from Libero and Designer's Start Menus and on the CD-ROM. From the Start menu choose:

- Programs > Libero x.x > Libero x.x Documentation.
- Programs > Designer Series > R2-2002 Documentation



Also, the online manuals are in PDF format on the CD-ROM in the “/manuals” directory. These manuals are also installed onto your system when you install the Designer software. To view the online manuals, you must install Adobe® Acrobat Reader® from the CD-ROM.

A complete list of the manuals that accompany the Designer series software is available at <http://www.actel.com/techdocs/manuals/index.htm>

## *Online Help*

The Designer Series software comes with online help. Online help specific to each software tool is available in Libero, Designer, ACTgen, ACTmap, Silicon Expert, Silicon Explorer II, Silicon Sculptor, and APSW.



---

# Generating Macros Using ACTgen

This chapter describes how to use the ACTgen Macro Builder, including information about generating new macros, modifying existing macros, using the Fan-In Control tool, and generating macro reports. Refer to the Actel Interface Guides for information about adding ACTgen macros to designs created with CAE tools.

## ACTgen Features

The ACTgen Macro Builder contains the following features:

### **Generate New Macros**

ACTgen can generate datapath macros that can be inserted as symbols into schematic designs or instantiated into synthesis-based designs.

### **Modify Existing Macros**

If you have previously generated an ACTgen macro for a design, ACTgen can modify this macro, changing the family or variations as desired.

### **Create HDL Behavioral Models**

If you are using an HDL synthesis-based design flow, ACTgen can create VHDL or Verilog behavioral models of macros for use in behavioral simulation prior to synthesis (though not for RAM blocks). Once the model has been simulated, you can then instantiate the macro into your design.

### **Fan-In Control**

If you need to control the buffering of clocks, asynchronous presets and clears, and other control signals in a macro, you can use the fan-in control tool to specify the type of buffering to use.

### **Macro Reports**

ACTgen stores information about a macro as it generates the macro. You can save and print this information when you generate the macro.

## ACTgen Main Window

When you invoke ACTgen, it displays the main window (as shown in Figure 1-1). The main window is blank until you create a new macro (from the File menu, select New, specify a device family) or open an existing file (from the File menu, select Open). After you create or open an existing file, specify the macro type you wish to generate and the variations of that macro.

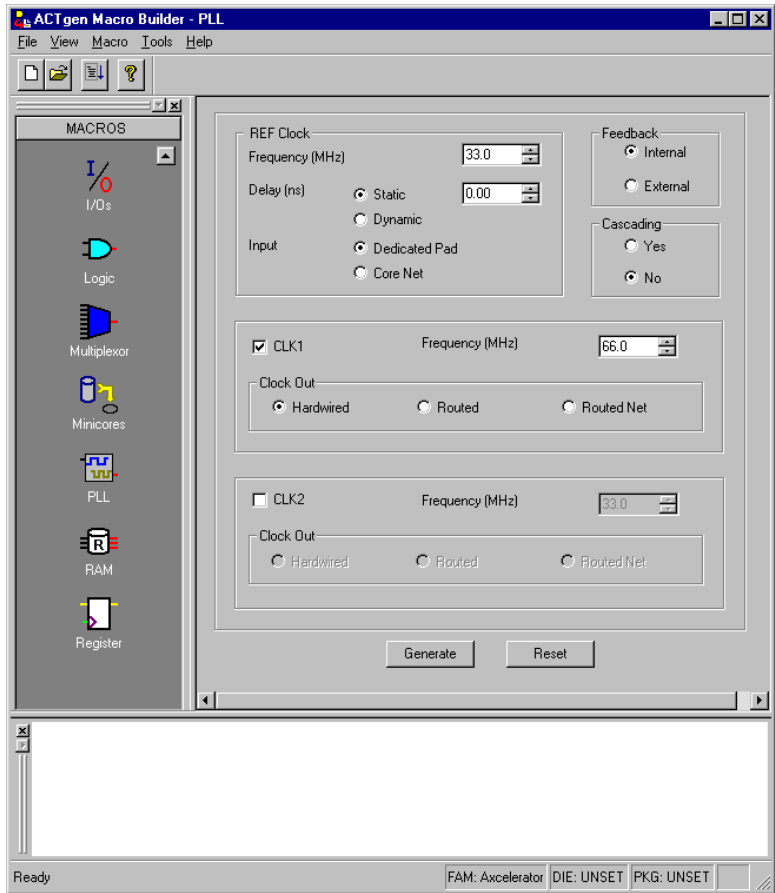

Figure 1-1. ACTgen Main Window (PLL Macro)

---

## Generating New Macros

Use the following procedure to generate a new macro with ACTgen.

**1. Invoke ACTgen.**

PC

Select ACTgen Macro Builder from the Designer menu under Programs in the Start menu.

UNIX

Type the following command at the prompt:

```
actgen
```

This displays the ACTgen Main window (as shown in Figure 1-1).

- 2. Open a new macro file.** From the File menu, select New, or click the New button.
- 3. Specify the Family.** Select the family of the Actel device the macro is to be used for in the Family pull-down menu.
- 4. Select the macro type to generate.** Click one of the macro type buttons, or select a macro from the Macro drop-down menu. Your choices of macro type vary according to the device you select. They include: Arithmetic, Comparators, Converter, Counters, Decoder, FIFO, I/Os, Logic, Multiplexor, Minicores, PLL, RAM, and Register.

5. **Specify the macro type.** Each type of macro may have several specific types available. Click the tab of the macro type you wish to generate (Figure 1-2). Click the arrows to view more macro types.

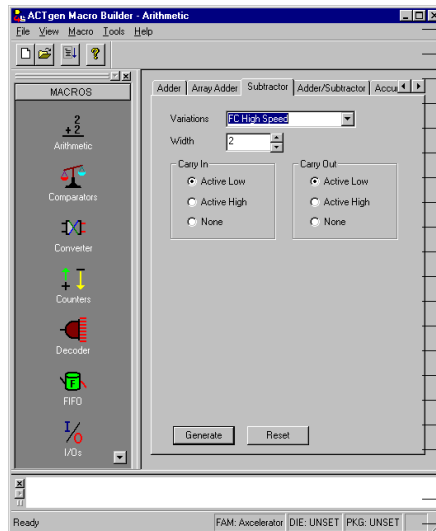

Figure 1-2. Macro Types - Arithmetic Macro

6. **Set macro variations.** The Variations drop-down menu displays options that are available for the specific macro type.
7. **(Optional) Set Fan-in Control.** If you wish to alter fan-in for control signals, specify the specific macro type and set macro variations first. Click the Fan-In Control button. This displays the Fan-In Control dialog box, shown in Figure 1-3. Set the desired buffering type and value for each signal. Refer to “Fan-in Control Tool” on page 17 for additional information.

**Note:** The Fan-In Control dialog box varies depending on the macro you are generating.

8. **Generate the macro.** Select the Generate command from the File Tool menu or click the Generate button on the toolbar. This displays the Generate Macro dialog box.
9. **(Optional) Generate a VHDL or Verilog behavioral model for the macro.** If your design is an HDL design and you want to perform a

---

behavioral simulation before synthesizing the design, check the appropriate option (in the Save dialog box) to generate a behavioral model for your macro.

**Note:** These options may not be available if the behavioral models are not available for the given selection.

- 10. Enter the name of your macro.** Type the path and name of your design in the File Name Box or use the Browse button.
- 11. Click OK.** The ACTgen Macro Builder generates the new macro with the specified options and displays information about the macro in the ACTgen Report window.

If you specified the netlist type as Viewlogic, Cadence, or Mentor Graphics, in addition to generating the macro, the ACTgen Macro Builder generates a symbol for the macro and displays the process on screen.

Your report is saved in the same directory as the netlist in a <design>.log file. The content of the report depends on the report options you select.

## *Modifying Existing Macros*

Use the following procedure to modify an existing macro.

### **1. Invoke ACTgen.**

PC

Select ACTgen Macro Builder from the Designer menu under Programs in the Start menu.

UNIX

Type the following command at the prompt:

```
actgen
```

This displays the ACTgen Main window, shown in Figure 1-1.

- 2. Open the macro to modify.** Choose the Open command from the File menu. The Open Macro dialog box appears. Type the name of the macro you want to open or use the Browse button.

3. **Modify the macro.** Change the family, macro type, specific macro type, and Variations as desired.
4. **(Optional) Set Fan-in Control.** If you wish to alter fan-in for control signals, specify the specific macro type and set macro variations first. Click the Fan-In Control button. This displays the Fan-In Control dialog box, shown in Figure 1-3. Set the desired buffering type and value for each signal. Refer to “Fan-in Control Tool” on page 17 for additional information.
5. **Re-generate the macro.** Select the Generate command from the File menu. This displays the Generate Macro dialog box.
6. **Select the output format from the Netlist/CAE Formats menu.** Choose the appropriate output format.

**Note:** The Cadence (Concept), Mentor Graphics, or Viewlogic format will not be in the Netlist/CAE Formats menu if these libraries were not installed when Designer was installed. CAE output formats are not available for the ProASIC family.

7. **(Optional) Generate a VHDL or Verilog behavioral model for the macro.** If your design is an HDL design and you want to perform a behavioral simulation before synthesizing the design, check the appropriate option check box to generate a behavioral model for your macro.

**Note:** These options may not be available if the behavioral models are not available for the given selection.

8. **Enter the name of your macro.** Type the path and name of your design in the File Name Box or use the Browse button.
9. **Click OK.** The ACTgen Macro Builder generates the new macro with the specified options and displays information about the macro in the ACTgen Report window.

If you specified the netlist type as Viewlogic, Cadence, or Mentor Graphics, in addition to generating the macro, the ACTgen Macro Builder generates a symbol for the macro and displays the process on screen. Symbols are not available for the ProASIC family.

10. **(Optional) Save your report.** In the ACTgen Macro Builder, save your report in \*.log format by choosing Save As in the Reports menu, or click the Save button on the toolbar. Name the file and click OK.



---

## *Fan-in Control Tool*

The Fan-in Control tool gives advanced users the ability to control the buffering of clocks, asynchronous presets and clears, and other control signals. This tool is optional because default buffering values are provided for all signals. The tool supports two types of buffering control, automatic and no buffering, which provide maximum buffering flexibility.

### ***Automatic Buffering***

Automatic buffering automatically inserts buffers as required, and provides ease of use for fanning out heavily loaded signals. Automatic buffering is the default buffering type for most signals. ACTgen automatically inserts buffers/inverters for this option and provides a single input for the signal. The value defined for automatic buffering indicates the maximum loading on the network for the given control signal. ACTgen also balances the loading as required. Automatic buffering can indirectly define input loading to a macro.

### ***No Buffering***

No buffering restricts ACTgen from inserting buffers. This allows designers to manually use global clock resources for control signals. This also provides the ability to enhance performance of control signals by performing a logic function and correcting for fan-in by duplicating logic external to the macro.

### ***Fan-in Control Tool Guidelines***

The Fan-in Control tool has the following limitations.

- The Fan-in Control tool has been designed to be a slave to the primary macro definition screen. Therefore, you should define exceptions to default values only after you have made all primary screen selections. Changing the main screen may affect the defined fan-in values. Information on modified fan-in will be provided in the Report window and should always be verified for correctness.
- The ability to perform no buffering on some control signals is limited to a single polarity because of hardware limitations. For example, ACT 2, 1200XL, ACT 3, 3200DX, 42MX, 54SX, 54SX-A, and eX limit asynchronous clears to Active Low only. Choosing Active High for this signal causes the No

Buffering option to be unavailable. When this situation occurs, go back to the primary screen and change the active level for the given signal if no buffering is a must.

- Some control signals, such as the Count Enable signal are not included in the Fan-in Control tool because fan-out is corrected internally using AND and OR logic functions.

## Using Fan-In Control

The Fan-in Control dialog box, shown in Figure 1-3, enables you to specify Auto Buffering or No Buffering, Max Load, and Signal Width.

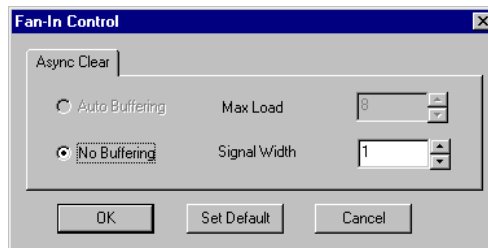

Figure 1-3. Fan-in Control Dialog Box

## Generating a Macro Report

As ACTgen generates a macro it writes information to the ACTgen Report window. The report contains information defining the macro, and is divided into the following sections:

- **Macro Parameter.** This section lists the options selected to build the macro.
- **Fan-in Control Information.** This section defines the type of buffering for each control signal and the values used to distribute the total load.

*To generate a .log file:*

ACTgen saves your report in the same directory as the netlist as a <design>.log file. The report content depends on which reports you choose to generate. You

---

may choose to generate a Compile report, a Timer report, or both. Click the appropriate checkbox in the Save dialog to generate the report.

## Preferences

Use the Preferences dialog box to set the Family, Netlist Type (VHDL, VERILOG etc.), start-up Directory and Report options. Whenever you try to Open a .gen file or generate a netlist, ACTgen uses the preferences you set here to generate your file.

*To set or modify your preferences:*

- 1. From the File menu, select Preferences.** The Preferences dialog box appears, as shown in Figure 1-4.

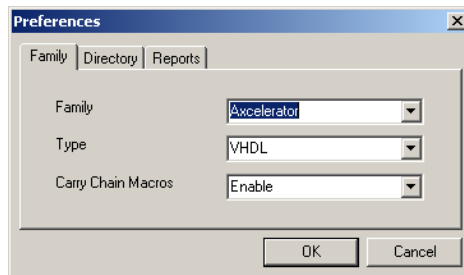

*Figure 1-4. Preferences Dialog Box - Family Tab*

Change your default family, type, and enable/disable carry chain macros from the Family tab. For more information on Fast Carry Chain Macros, please see “Fast Carry Chains (Axcelerator Only)” on page 20.

2. **Change your default directory.** Click the Directory tab to change your default working directory, as in Figure 1-5.

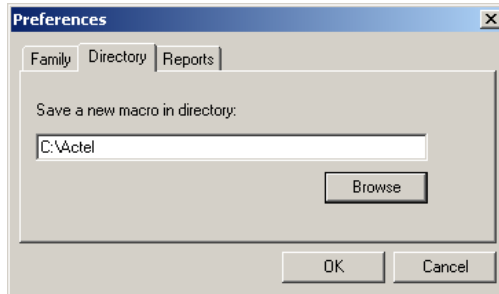

Figure 1-5. Preferences Dialog Box - Directory Tab

3. **Enable or disable your reports.** Use the Reports tab to enable or disable your Timer and Compile reports. Click the checkbox to enable the reports, leave empty to disable (Figure 1-6).

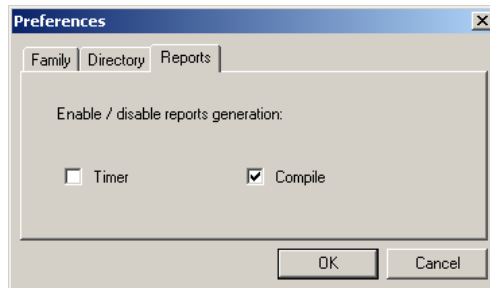

Figure 1-6. Preferences Dialog Box - Reports Tab

## Fast Carry Chains (Axcelerator Only)

The Axcelerator Family offers fast carry-chain macros for a compact design of Arithmetic Macros and Counters. FC macros for Axcelerator are enabled by default. You may choose to use regular macros for the Axcelerator family; to do so, open the Preferences dialog box to the Family tab (Figure 1-4). Select Disable from the “Carry Chain Macros” drop down menu to disable Fast Carry

---

Chain macros. To enable both types of macros (regular and fast carry chain), select Add-on from the drop down menu (Figure 1-7).

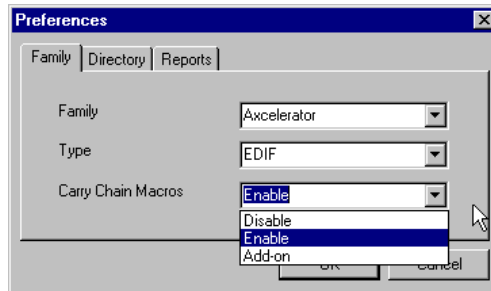

*Figure 1-7. Setting Fast Carry Chain Macro Preferences*

You can generate FC macros via the ACTgen module generator or infer them via Actel's Synopsys Designware (DWACTION). FC macros are always the most area-efficient way to implement these modules. They are superior in performance for up to 32 bit, although some modules may be inferior beyond 32 bit (incrementors, for example). Though ACTgen offers both architecture types (FC macros and non-FC macros), Actel recommends you use FC macros to guarantee area efficiency.

In the ACTgen GUI you can distinguish the FC macros from non-FC macros by the prefix "FC" (e.g. "FC High Speed" versus "High Speed"). The macro parameters used in the .gen-file also use "FC" for distinction. For example the "High Speed" adder using fast carry chains would be specified through:

```
LPMTYPE:LPM_FC_ADD_SUB  
LPM_HINT:FC_FADD
```

whereas the corresponding non-FC version would be specified through:

```
LPMTYPE:LPM_ADD_SUB  
LPM_HINT:FADD
```

**PDF Reader (UNIX only)** - Use the PDF Reader tab to bring up ACTgen's online manuals. Enter the default reader's name with the full path or click Browse.

**Web Browser (UNIX only)** - Use the Web Browser tab to change the default web browser on UNIX machines. Enter the new browser's name with the full path, or click Browse. ACTgen uses the web browser to bring up the HTML display of data in the software-versioning feature (when such data needs to be displayed) as well as supporting the Actel-on-the-Web feature.

If you wish to change the family for a particular session, from the File menu click New, or click the New button on the toolbar. This opens the New Macro dialog box and enables you to select a new family. It does not update the Preferences.

## PortMapping Dialog

Some macros have a high number of input and output signals. You can use the PortMapping function to specify the port naming for macros with a high number of input and output signals. Click the PortMapping button (Figure 1-8) to open the Port Mapping dialog box.

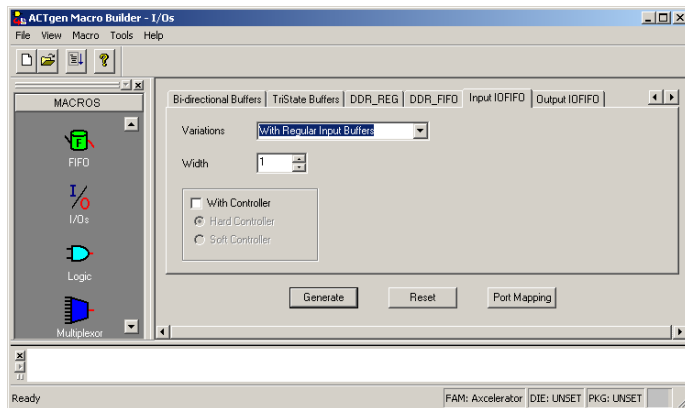
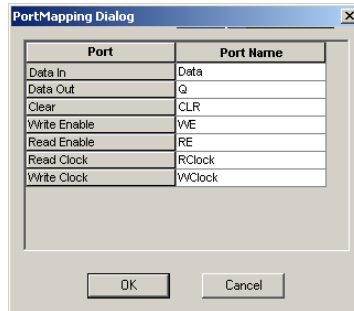

Figure 1-8. Port Mapping Button in Input IOFIFO Dialog Box

---

The PortMapping Dialog (Figure 1-9) appears and displays the port name default values. Enter changes and click OK to submit, or click Cancel to return to the default values.



*Figure 1-9. PortMapping Dialog Box*

## Calling ACTgen in Batchmode

For scripting purposes you may wish to call ACTgen in batchmode. If actgen is in the search path, this can be done on both UNIX or Windows with the command line:

```
actgen BATCH:T [GENFILE:<filename>] <macroname>
```

<macroname> is the name given to the generated macro files that ACTgen produces in the current directory; for example, <macroname>.log and a netlist, <macroname>.edn (if you specified the EDIF output format).

If you do not specify a genfile ACTgen assumes <macroname>.gen. <filename> is a macro generation file that describes the macro type, attributes, family, output file format, and other information. Each line of the genfile contains:

```
variable:value
```

Details on genfile contents are described later in this document for each macro type. An alternative to writing a genfile is that all mandatory macro parameters could be given directly on the command line. ACTgen command-line arguments are not case sensitive, however Actel recommends that you use the same cases as written out by ACTgen.

The return code from the Windows or UNIX batch is 0 on success or nonzero on failure.

Table 1-1 lists the variables that control the generation of behavioral models and reports.

*Table 1-1. ACTgen Batchmode Behavioral Models and Reports*

<b>PARAMETER</b>	<b>Value</b>	<b>Description</b>
GEN_BHV_VHDL_VAL	T F	Generate VHDL behavioral model, if available
GEN_BHV_VERILOG_VAL	T F	Generate Verilog behavioral model, if available
MGNCMPL	T F	Compile report on/off
MGNTIMER	T F	Prolate timer report on/off



---

*Arithmetic Macros*

# Adder

## Features

- Parameterized word length
- Optional carry-in and carry-out signals
- Multiple gate-level implementations (speed/area tradeoffs)
- Behavioral simulation model in VHDL and Verilog

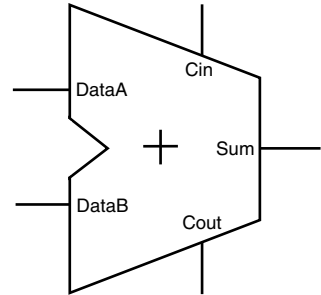

## Family Support

ACT 1, ACT 2/1200XL, ACT 3, 3200DX, 40MX, 42MX, 54SX, 54SX-A, eX, 500K, PA, 500K, Axcelerator

## Description

Table 2-1. Port Description

Port Name	Size	Type	Req/Opt	Function
DataA	WIDTH	Input	Req.	Input Data
DataB	WIDTH	Input	Req.	Input Data
Cin	1	Input	Opt.	Carry-in
Sum	WIDTH	Output	Req.	Sum
Cout	1	Output	Opt.	Carry-out

Table 2-2. Parameter Description

Parameter	Family	Value	Function
WIDTH <sup>a</sup>	500K, PA	2-128	Word length of DataA, DataB and Sum
	Axcelerator	2-156	
	Other	2-32	
MAXFANOUT	500K, PA	0	Automatic choice (function of WIDTH)
		2-16	Manual setting of Max. Fanout
CI_POLARITY	ALL	0 1 <b>2</b>	Carry-in polarity (active high, active low and not used)

Table 2-2. Parameter Description

Parameter	Family	Value	Function
CO_POLARITY	ALL	0 1 2	Carry-out polarity (active high, active low and not used)

a. The Brent-Kung Adder extends the ranges from 32 to 128 bit for 54SX, 54SX-A and from 20 to 128 bit for 500K

The MAXFANOUT parameter enables you to perform logic replication for all ProASIC Adders, Subtractors, Adder/Subtractors and Accumulators. Inherently only the Sklansky algorithm generates high-fanout nets (max. fanout = WIDTH/2), so you will see effects only for this algorithm. The area increases exponentially for MAXFANOUT approaching 2 and it flattens out for higher values, as shown in Figure 2-1.

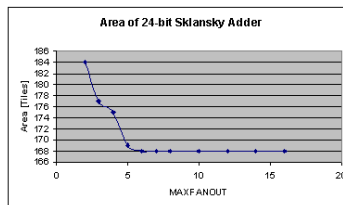

Figure 2-1. Adder Area as a Function of MAX FANOUT

Performance is not always as predictable (as shown in Figure 2-2). When you select automatic logic replication, ACTgen automatically chooses a value for MAXFANOUT based on WIDTH. This value returns a good, but not necessarily the best, result for that particular value of WIDTH.

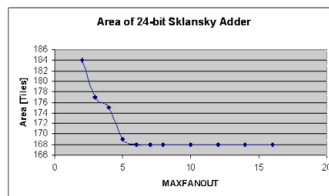

Figure 2-2. Adder Performance as a Function of MAX FANOUT

Table 2-3. Implementation Parameters

Parameter	Family	Value	Description
LPMTYPE	ALL	LPM_ADD_SUB	Adder category
LPM_HINT	500K, PA	SKADD	Sklansky model
		FBKADD	Fast Brent-Kung model
		BKADD	(Compact) Brent-Kung model
	ALL	FADD	Very fast carry select model
		MFADD	Fast carry select model
		RIPADD	Ripple carry model
LPMTYPE	Axcelerator	LPM_FC_ADD_SUB	Fast carry chain Adder category
LPM_HINT	Axcelerator	FC_FADD	Fast carry chain selct model
		FC_RIPADD	Fast carry chain ripple carry model

Table 2-4. Functional Description

DataA	DataB	Sum	Cout <sup>a</sup>
m[width-1 : 0]	n[width-1 : 0]	(m + n + Cin)[width-1 : 0]	(m + n + Cin)[width]

a. Cin and Cout are assumed to be active high

---

# Array Adder

## Features

- Parameterized word length and number of input buses
- DADDA tree architecture with optional Final Adder
- Optional pipeline for implementation with Final Adder
- Behavioral simulation model in VHDL and Verilog

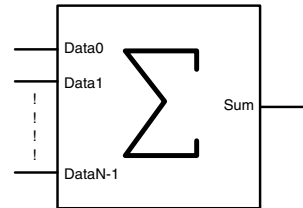

## Family Support

54SX, 54SX-A, eX, 500K, PA

## Description

The Array-Adder implements a Sum-Function over an Array of Buses:

$$\text{Sum} = \sum \text{Data}(i) \quad \text{where } i = (0 \text{ to } \text{SIZE}-1)$$

In applications where designers have to add more than two operands at a time “Carry-Save- Techniques” might be used to build the final Sum. ACTgen makes these techniques available through the Array-Adder macro, which is using a Dadda tree algorithm. Usually this algorithm is more compact and faster than using Adder-trees consisting of multiple 2-operand adders, especially if the number of operands gets large and/or for large word width.

An example could be the FIR-filter architecture using a “distributed arithmetic” as described in the Application Note from September 1997 “Designing FIR Filters with Actel FPGAs.” This architecture generates a large number of partial products, which need to be summed up. Summing them up in an Adder-Tree would both be slow and area expensive. At the time of writing this document synthesis tools did not infer Multiple-Operand-Adders. Therefore making use of the Array-Adder in those types of applications might result in a significant gain in both speed and area.

The Array Adder comes with or without Final Adder. The version with Final Adder allows to instantiate a pipeline stage between the Dadda-tree and the Final Adder. The output bitwidth for Sum can be calculated using this formula:

$$\text{OUTWIDTH} = \log_2((m * \exp_2(n) - 1) + 1) \leq n + \log_2(m)$$

The version without Final Adder has two output ports: SumA and SumB, which added together, will provide the Final Result. It is

SumA\_Width <= SumB\_Width <= OUTWIDTH

The differences are at most one bit. This variation of the Array-Adder is particularly useful for an application, which would cascade the Array-Adder. In that case only the last stage would need a Final Adder to build the result.

Table 2-5. Port Description

Port Name	Size	Type	Req/Opt	Function
Data0	WIDTH	Input	Req.	Input Data (Operand 0)
Data1	WIDTH	Input	Req.	Input Data (Operand 1)
Data2	WIDTH	Input	Req.	Input Data (Operand 2)
Data <sub>x</sub>	WIDTH	Input	Opt.	Input Data (Operand X) X>2
Sum	OUT-WIDTH	Output	Req.	$\sum \text{Data}(i) \rightarrow i = 0 \text{ to } \text{SIZE}-1$
Clock	1	Input	Opt.	Clock (if pipelined)

Table 2-6. Parameter Description

Parameter	Value	Function
WIDTH	width	Word length Data(i)
SIZE	size	Number of input buses
CKL_EDGE	RISE FALL	Clock (if pipelined)

Table 2-7. Implementation Parameters

Parameter	Value	Description
LPMTYPE	DADDA	Generic Array Adder category
LPM_HINT	ARRADD	Array Adder with Final Adder
	ARRADDP	Pipelined Array Adder with Final Adder

*Table 2-7. Implementation Parameters*

Parameter	Value	Description
	ARRADD2	Array Adder without Final Adder

*Table 2-8. Parameter Rules*

Family	Variation	Parameter Rules
eX	ARRADD / ARRADDP	WIDTH * SIZE <=870
	ARRADD2	WIDTH * SIZE <= 930
SX	ARRADD / ARADDP	WIDTH * SIZE <=110
	ARRADD2	WIDTH * SIZE <=144

# Subtractor

## Features

- Parameterized word length
- Optional carry-in and carry-out signals
- Multiple gate-level implementations (speed/area tradeoffs)
- Behavioral simulation model in VHDL and Verilog

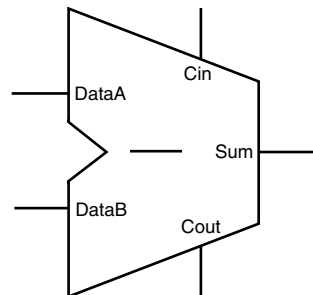

## Family Support

ACT 1, ACT 2/1200XL, ACT 3, 3200DX, 40MX, 42MX, 54SX, 54SX-A, eX, 500K, PA, Axcelerator

## Description

Table 2-9. Port Description

Port Name	Size	Type	Req/Opt	Function
DataA	WIDTH	Input	Req.	Input Data
DataB	WIDTH	Input	Req.	Input Data
Cin	1	Input	Opt.	Carry-in
Sum	WIDTH	Output	Req.	Sum
Cout	1	Output	Opt.	Carry-out

Table 2-10. Parameter Description

Parameter	Family	Value	Function
WIDTH <sup>a</sup>	500K, PA	2-128	Word length of DataA, DataB and Sum
	Axcelerator	2-156	
	Other	2-32	
MAXFANOUT	500K, PA	0	Automatic choice (function of WIDTH)
		2-16	Manual setting of Max. Fanout



Table 2-10. Parameter Description (Continued)

Parameter	Family	Value	Function
CI_POLARITY	ALL	0 1 2	Carry-in polarity (active high, active low and not used)
CO_POLARITY	ALL	0 1 2	Carry-out polarity (active high, active low and not used)

a. The Brent-Kung Adder extends the ranges from 32 to 128 bit for 54SX, 54SX-A and from 20 to 128 bit for 500K

Table 2-11. Implementation Parameters

Parameter	Family	Value	Description
LPMTYPE	ALL	LPM_ADD_SUB	Subtractor category
LPM_HINT	500K, PA	SKSUB	Sklansky model
		FBKSUB	Fast Brent-Kung model
		BKSUB	(Compact) Brent-Kung model
	ALL	FSUB	Very fast carry select model
		MFSUB	Fast carry select model
		RIPSUB	Ripple carry model
LPMTYPE	Axcelerator	LPM_FC_ADD_SUB	Fast carry chain Subtractor category
LPM_HINT	Axcelerator	FC_FSUB	Fast carry chain selct model
		FC_RIPSUB	Fast carry chain ripple carry model

Table 2-12. Functional Description

DataA	DataB	Sum	Cout <sup>a</sup>
m[width-1 : 0]	n[width-1 : 0]	(m - n - Cin) [width-1 : 0]	(m - n - Cin)[width]

a. Cin and Cout are assumed to be active high

# Adder/Subtractor

## Features

- Parameterized word length
- Optional carry-in and carry-out signals
- Multiple gate-level implementations (speed/area tradeoffs)
- Behavioral simulation model in VHDL and Verilog

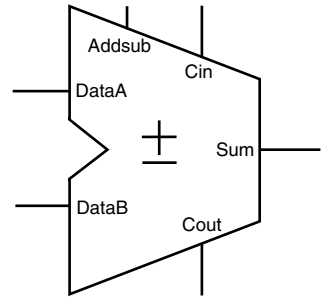

## Family Support

ACT 1, ACT 2/1200XL, ACT 3, 3200DX, 40MX, 42MX, 54SX, 54SX-A, eX, 500K, PA, Axcelerator

## Description

Table 2-13. Port Description

Port Name	Size	Type	Req/Opt	Function
DataA	WIDTH	Input	Req.	Input Data
DataB	WIDTH	Input	Req.	Input Data
Cin	1	Input	Opt.	Carry-in
Sum	WIDTH	Output	Req.	Sum
Cout	1	Output	Opt.	Carry-out
Addsub	1	Input	Req.	Addition (AddSub = 1) or subtraction (Addsub = 0)

Table 2-14. Parameter Description

Parameter	Family	Value	Function
WIDTH <sup>a</sup>	500K, PA	2-128	Word length of DataA, DataB and Sum
	Axcelerator	2-156	
	Other	2-32	
MAXFANOUT	500K, PA	0	Automatic choice (function of WIDTH)
		2-16	Manual setting of Max. Fanout

Table 2-14. Parameter Description

Parameter	Family	Value	Function
CI_POLARITY	ALL	0 1 2	Carry-in polarity (active high, active low, and not used)
CO_POLARITY	ALL	0 1 2	Carry-out polarity (active high, active low, and not used)

a. The Brent-Kung Adder extends the ranges from 32 to 128 bit for 54SX, 54SX-A and from 20 to 128 bit for 500K

Table 2-15. Implementation Parameters

Parameter	Family	Value	Description
LPMTYPE	ALL	LPM_ADD_SUB	Adder/Subtractor category
LPM_HINT	500K, PA	SKADDSUB	Sklansky model
		FBKADDSUB	Fast Brent-Kung model
		BKADDSUB	(Compact) Brent-Kung model
	ALL	FADDSUB	Very fast carry select model
		MFADDSUB	Fast carry select model
		RIPADDSUB	Ripple carry model
LPMTYPE	Axcelerator	LPM_FC_ADD_SUB	Fast carry chain Adder category
LPM_HINT	Axcelerator	FC_FADDSUB	Fast carry chain select model
		FC_RIPADDSUB	Fast carry chain ripple carry model

Table 2-16. Functional Description

DataA	DataB	Addsub	Sum	Cout <sup>a</sup>
m[width-1 : 0]	n[width-1 : 0]	(m + n + Cin)[width-1 : 0]	(m + n + Cin)[width]	m[width-1 : 0]
m[width-1 : 0]	n[width-1 : 0]	(m - n - Cin)[width-1 : 0]	(m - n - Cin)[width]	m[width-1 : 0]

a. Cin and Cout are assumed to be active high here.

# Accumulator

## Features

- Parameterized word length
- Optional carry-in and carry-out signals
- Asynchronous reset
- Accumulator enable
- Multiple gate-level implementations (speed/area tradeoffs)
- Behavioral simulation model in VHDL and Verilog

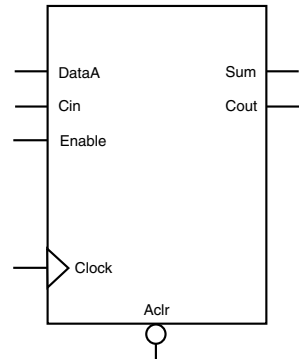

## Family Support

ACT 1, ACT 2/1200XL, ACT 3, 3200DX, 40MX, 42MX, 54SX, 54SX-A, eX, PA, 500K, Axcelerator

## Description

Table 2-17. Port Description

Port Name	Size	Type	Req/Opt	Function
DataA	WIDTH	Input	Req.	Input Data
Cin	1	Input	Opt.	Carry-in
Sum	WIDTH	Output	Req.	Sum
Cout	1	Output	Opt.	Carry-out
Enable	1	Input	Opt	Enable
Clock	1	Input	Req.	Clock
Aclr	1	Input	Opt	Asynchronous Reset

Table 2-18. Parameter Description

Parameter	Family	Value	Function
WIDTH <sup>a</sup>	500K, PA	2-128	Word length of DataA, DataB and Sum
	Axcelerator	2-156	
	Other	2-32	
MAXFANOUT	500K, PA	0	Automatic choice (function of WIDTH)
		2-16	Manual setting of Max. Fanout
CI_POLARITY	ALL	0 1 <b>2</b>	Carry-in polarity (active high, active low, and not used)
CO_POLARITY	ALL	0 1 <b>2</b>	Carry-out polarity (active high, active low, and not used)
CLR_POLARITY	ALL	<b>0</b> 1 2	Asynchronous reset (active high, active low, and not used)
EN_POLARITY	ALL	0 <b>1</b> 2	Accumulator enable (active high, active low, and not used)
CLK_EDGE	ALL	<b>RISE</b> FALL	

a. The Brent-Kung Adder extends the ranges from 32 to 128 bit for 54SX, 54SX-A and from 20 to 128 bit for 500K

Table 2-19. Fan-in Control Parameters

Parameter	Value
CLR_FANIN	<b>AUTO</b> MANUAL
CLR_VAL	<val> [default value for AUTO is 8, 1 for MANUAL]
EN_FANIN	<b>AUTO</b> MANUAL
EN_VAL	<val> [default value for AUTO is 6, 1 for MANUAL]
CLK_FANIN	AUTO <b>MANUAL</b>
CLK_VAL	<val> [default value for AUTO is 8, 1 for MANUAL]

Table 2-20. Implementation Parameters

Parameter	Family	Value	Description
LPMTYPE		LPM_ADD_SUB	Accumulator category
LPM_HINT	500K, PA	SKACC	Sklansky model
		FBKACC	Fast Brent-Kung model
		BKACC	(Compact) Brent-Kung model
	ALL	FACC	Very fast carry select model
		MFACC	Fast carry select model
		RIPACC	Ripple carry model
LPMTYPE	Axcelerator	LPM_FC_ADD_SUB	Fast carry chain Adder category
LPM_HINT	Axcelerator	FC_FACC	Fast carry chain select model
		FC_RIPACC	Fast carry chain ripple carry model

Table 2-21. Functional Description

DataA	Sum <sub>n+1</sub>	Cout <sup>a</sup>
m[width-1 : 0]	(m + Sum <sub>n</sub> + Cin)[width-1 : 0]	(m + Sum <sub>n</sub> + Cin)[width]

a. Cin and Cout are assumed to be active high.

---

# Incrementer

## Features

- Parameterized word length
- Optional Carry-out signals
- One very fast gate level implementation
- Behavioral simulation model in VHDL and Verilog

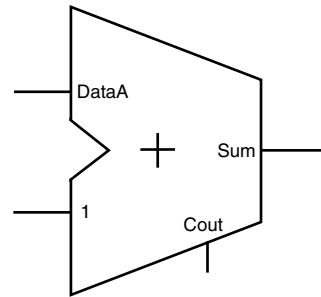

## Family Support

ACT 2/1200XL, ACT 3, 3200DX, 42MX, 54SX, 54SX-A, eX, 500K, PA

## Description

*Table 2-22. Port Description*

Port Name	Size	Type	Req/Opt	Function
DataA	WIDTH	Input	Req.	Input Data
Sum	WIDTH	Output	Req.	Sum
Cout	1	Output	Opt.	Carry-out

*Table 2-23. Parameter Description*

Parameter	Value	Function
WIDTH	2-32	Word length of DataA and Sum
CO_POLARITY	0 1 2	Carry-out polarity (active high, active low, and not used)

*Table 2-24. Implementation Parameters*

<b>Parameter</b>	<b>Value</b>	<b>Description</b>
LPMTYPE	LPM_ADD_SUB	Incrementer category
LPM_HINT	FINC	Very fast carry look ahead

*Table 2-25. Functional Description*

<b>DataA</b>	<b>Sum</b>	<b>Cout</b>
m	m + 1	$(m + 1) \geq 2^{\text{width}}$



---

# Decrementer

## Features

- Parameterized word length
- Optional Carry-out signals
- One very fast gate level implementation
- Behavioral simulation model in VHDL and Verilog

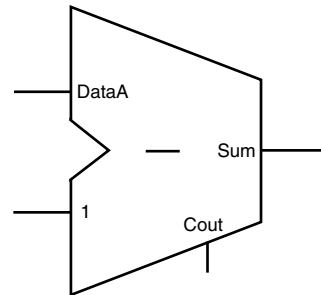

## Family Support

ACT 2/1200XL, ACT 3, 3200DX, 42MX, 54SX, 54SX-A, eX, 500K, PA

## Description

Table 2-26. Port Description

Port Name	Size	Type	Req/Opt	Function
DataA	WIDTH	Input	Req.	Input Data
Sum	WIDTH	Output	Req.	Sum
Cout	1	Output	Opt.	Carry-out

Table 2-27. Parameter Description

Parameter	Value	Function
WIDTH	2-32	Word length of DataA and Sum
CO_POLARITY	0 1 2	Carry-out polarity (active high, active low, and not used)

*Table 2-28. Implementation Parameters*

<b>Parameter</b>	<b>Value</b>	<b>Description</b>
LPMTYPE	LPM_ADD_SUB	Decrementer category
LPM_HINT	FDEC	Very fast carry look ahead

*Table 2-29. Functional Description*

<b>DataA</b>	<b>DataB</b>	<b>Sum</b>	<b>Cout</b>
m	n	m - 1	(m-1) < 0

# Incrementer/Decrementer

## Features

- Parameterized word length
- Optional Carry-out signals
- One very fast gate level implementation
- Behavioral simulation model in VHDL and Verilog

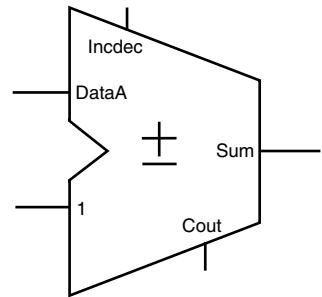

## Family Support

ACT 2/1200XL, ACT 3, 3200DX, 42MX, 54SX, 54SX-A, eX, 500K, PA

## Description

Table 2-30. Port Description

Port Name	Size	Type	Req/Opt	Function
DataA	WIDTH	Input	Req.	Input Data
Sum	WIDTH	Output	Req.	Sum
Cout	1	Output	Opt.	Carry-out
Incdec	1	Input	Req.	Increment (Incdec = 1) or decrement (Incdec = 0)

Table 2-31. Parameter Description

Parameter	Value	Function
WIDTH	2-32	Word length of DataA and Sum
CO_POLARITY	0 1 <b>2</b>	Carry-out polarity (active high, active low, and not used)

*Table 2-32. Implementation Parameters*

<b>Parameter</b>	<b>Value</b>	<b>Description</b>
LPMTYPE	LPM_ADD_SUB	Incrementer/Decrementer category
LPM_HINT	FINCDEC	Very fast carry look ahead

*Table 2-33. Functional Description*

<b>DataA</b>	<b>Incdec</b>	<b>Sum</b>	<b>Cout</b>
m	1	m + 1	$(m + 1) \geq 2^{\text{width}}$
m	0	m - 1	$(m - 1) < 0$

---

# Constant Multiplier

## Features

- Parameterized word lengths and constant values
- Unsigned and signed (two's complement) data representation
- Booth / Wallace architecture
- Behavioral simulation model (for non-pipelined multiplier only) in VHDL and Verilog

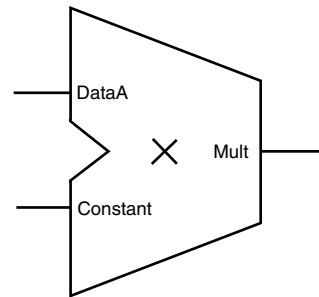

## Family Support

54SX, 54SX-A, eX, 500K, PA

## Description

The Constant Multiplier performs the multiplication of a data-input with a constant value. Area and performance of the Constant Multiplier depend on the value of the constant. Specifically, area and performance depend on the number of groups of 1's in the bit pattern of the constant. As a result, the worst-case constant has a bit pattern of alternating 1's and 0's (...010101...). However, even for that worst case the area and performance of the Constant Multiplier is superior to a regular Multiplier.

The Constant Multiplier macro output wordlength is always double the input wordlength. Depending on the value of the constant, some of the most significant bits might be sign-extension bits. You may be able to reduce hardware by calculating the actual number of bits needed and cutting all sign-extension bits. For example:

width =4, Constant = 1100, representation=signed

The worst case data for this example would be 1000 (-8) and therefore the worst case output data would be 010 0000 (-8 \* -4 = 32). So with that we know, that Mult<8> is just a sign-extension bit (Mult<8> = Mult<7>).

Keep in mind that some constant multiplications might be generated even more effectively, e.g. constants to the power of 2 are just shift-operations, or constants like 3,5,7,9,10, etc. can be generated using shift operations and a simple addition/subtraction (2+1, 4+1, 8-1, 8+1, 8+2, etc.). For these constants the implementation of the Constant Multiplier might not be as efficient as using shift operations and/or Adders/Subtractors.

Usually synthesis infers regular Multipliers even for constant values. Therefore the use of the Constant Multiplier macro in a design, which performs one or more multiplications with constant values, is expected to be very beneficial.

An application example might be FIR-filters with constant coefficients, where the computation is organized in the “transposed form” as indicated in Figure 2-3.

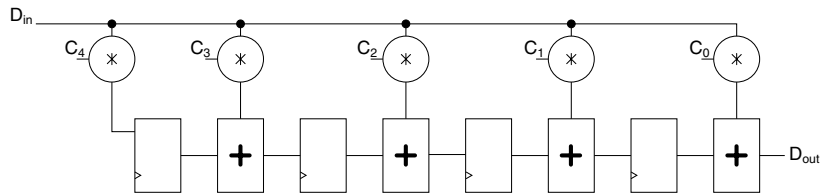

Figure 2-3. FIR-filter Organized in the "Transposed Form" Using Constant Multipliers

Table 2-34. Port Description

Port Name	Size	Type	Req/Opt	Function
Data	WIDTH	Input	Req.	Input data
Mult	2*WIDTH	Output	Req.	Constant * Data

Table 2-35. Parameter Description

Parameter	Value	Function
WIDTH <sup>a</sup>	2-64	Word length Data
CONST	Constant	Constant value
RADIX	HEX BIN DEC	Radix for constant value
SIGN <sup>b</sup>	0 1	Positive, negative constant sign

a. For eX WIDTH is supported from 2-11

b. For signed constant multiplier

Parameter Rules:

1. DataA is always binary and of the size of Width.
2. Constant must be of the selected Radix and be of the selected width for HEX/BIN.

e.g.: Radix: BIN, Width: 5, Constant: 00010

Radix Hex, Width:8, Constant: 0A

*Table 2-36. Implementation Parameters*

<b>Parameter</b>	<b>Value</b>	<b>Description</b>
LPM_TYPE	LPM_MULT	Constant multiplier category
LPM_HINT	UCMULT	Unsigned constant multiplier
	SCMULT	Signed constant multiplier

---

# Multiplier

## Features

- Parameterized word lengths
- Unsigned and signed (two's complement) data representation
- Booth or array implementation
- Optional pipelining
- Behavioral simulation model in VHDL and Verilog

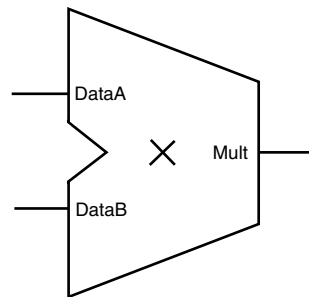

## Family Support

ACT 2/1200XL, ACT 3, 3200DX, 42MX, 54SX, 54SX-A, eX, 500K, PA, Axcelerator<sup>1</sup>

## Description

Table 2-37. Port Description

Port Name	Size	Type	Req/Opt	Function
DataA	WIDTHA	Input	Req.	Input data
DataB	WIDTHB	Input	Req.	Input data
Clock	1	Input	Opt.	Clock
Mult	WIDTHA+WIDTHB	Output	Opt.	DataA*DataB
Mult0	WIDTHA+WIDTHB	Output	Opt.	Mult0 + Mult1 = DataA*DataB
Mult1	WIDTHA+WIDTHB	Output	Opt.	

---

1. For more information on the Fast Carry Chain macros available with the Axcelerator family, please refer to “Fast Carry Chains (Axcelerator Only)” on page 20.



Table 2-38. Parameter Description

Parameter	Family	Value	Function
WIDTHA <sup>a</sup>	500K, PA, Accelerator	2-64	Word length of DataA
	eX	2-14	
	Other	2-30	
WIDTHB	Same as WIDTHA		Word length of DataB
REPRESENTATION		<b>UNSIGNED</b> <b>SIGNED</b>	Data representation
CLK_EDGE		<b>RISE</b> <b>FALL</b>	Clock (if pipelined)

a. For some of the multiplier variations there are small deviations from the limits mentioned to insure that the multiplier fits in the largest device of the selected family.

Table 2-39. Functional Description

DataA	DataB	Mult1 <sup>a</sup>
m	n	m * n

a. If pipelined, the sum is correct (available) after <latency> cycles. Latency is a function of WIDTHA and WIDTHB, or the number of pipelined stages mentioned specifically (eg. 1 or 2 pipelines).

Table 2-40. Functional Description

DataA	DataB	Mult0/1 <sup>a</sup>
m	n	Mult1 + Mult2 = m * n

a. Mult1<0> is always 0

Table 2-41. Parameter Rules<sup>a</sup>

Family	Variation	Parameter rules
All	All	WIDTHA ≥ WIDTHB
eX	BOOTHMULT/P	WIDTHA + WIDTHB ≤ 15 (signed) / 16 (unsigned)
	BOOTHMULTP	For TMR restrictions for WIDTHA, WIDTHB
	BOOTHMULT2	WIDTHA + WIDTHB ≤ 17 (signed) / 18 (unsigned)
SX/SX-A	BOOTHMULT/P	WIDTHA + WIDTHB ≤ 32
	BOOTHMULT2	WIDTHA + WIDTHB ≤ 55
Axcelerator	ARRAYMULT	WIDTHA + WIDTHB ≤ 128
	PARRAYMULT	WIDTHA + WIDTHB ≤ 128
	FC_BOOTHMULT1	WIDTHA + WIDTHB ≤ 106
	FC_BOOTHMULT1	WIDTHA + WIDTHB ≤ 106
500K, PA	All	WIDTHA + WIDTHB ≤ 106
Other	All	WIDTHA + WIDTHB ≤ 32

a. These are the most important parameter rules; additional rules may apply

Table 2-42. Implementation Parameters

Parameter	Value	Description
LPMTYPE	LPM_MULT	Multiplier category
LPM_HINT	BOOTHMULT	Booth multiplier
	BOOTHMULT2 <sup>a</sup>	Booth multiplier without final Adder
	BOOTHMULTP	Pipelined booth multiplier
LPMTYPE	LPM_FC_MULT	Fast Carry multiplier category (Axcelerator) <sup>b</sup>
	PARRAYMULT	Fast Carry array multipliers in parallel; each array multiplier consists of a 1-bit multiplier (MULT1); the rows of the array use fast carry chains, but there is a regular routing between columns
	BOOTHMULT1	Booth-encoded Wallace-tree with Fast Carry final adder
	BOOTHMULT2	Booth-encoded multiplier with n-bit Fast Carry adder tree

a. Available for 54SX, 54SX-A, eX, 500K & PA (ProASIC)

b. For information on multiplier area and performance please refer to the latest Actel application note available at <http://www.actel.com>

Table 2-43. Axcelerator Multiplier Architecture Comparison Speed<sup>a</sup>

Architecture \ Speed	1 (fastest)	2	3 (slowest)
Parallel-2 Array Multiplier	width <= 8 bit	8 bit < width <= 10 bit	width > 10 bit
FC Booth-1	8 bit < width <= 20 bit	width <= 8 bit or width > 20 bit	
FC Booth-2	width > 20 bit	10 bit < width <= 20 bit	width <= 10 bit

a. For simplicity's sake, the table assumes WIDTHA = WIDTHB = width

Table 2-44. Axcelerator Multiplier Architecture Comparison: Area

Architecture \ Speed	1 (smallest)	2	3 (largest)
Parallel-2 Array Multiplier	always		
FC Booth-1			always
FC Booth-2		always	

## Advanced Options

Click the Advanced button (available for PA, 500K, and Axcelerator devices) to specify pipeline stages. If you are using a PA or 500K device, you can insert (default setting) or omit the final Adder stage.

### Omitting the Final Adder

You can choose not to instantiate the final adder in the multiplier and add up the two buses Mult0 and Mult1 to the final result later in the design flow. This is often the most efficient implementation when a lot of partial results get summed up in a large summation network. Figure 2-4 shows an example for  $Y = (A \times B) + C + D$  using the multiplier with 2 outputs in combination with the Array-Adder.

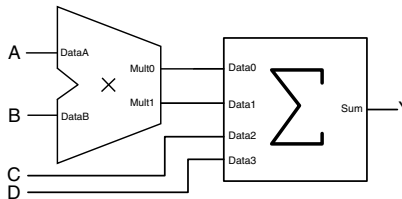

Figure 2-4. Efficient implementation using the 2-output multiplier in combination with the Array-Adder

## Multiplier Pipelining

For 500K, PA and Accelerator devices you can specify the number of pipeline stages (1, 2, or 3). However, three pipeline stages increases performance only for high bitwidth. Click the Advanced button in the GUI to access pipelining.

Table 2-45. Pipeline Stages

Pipeline Stages	WidthB	
	w/ Final Adder	w/o Final Adder
1	$\geq 2$	$\geq 5$
2	$\geq 5$	$\geq 7$
3	$\geq 7$	Not applicable

For ACT 2/1200XL, ACT 3, 3200DX, 42MX, 54SX, 54SX-A, eX the multiplier architecture does not allow you to select the latency of the pipelined multiplier or the number of logic levels between the pipeline stages. Registers are automatically inserted between the major components of the architecture, primarily the multiplexer and adder macros, as shown in Figure 2-5.

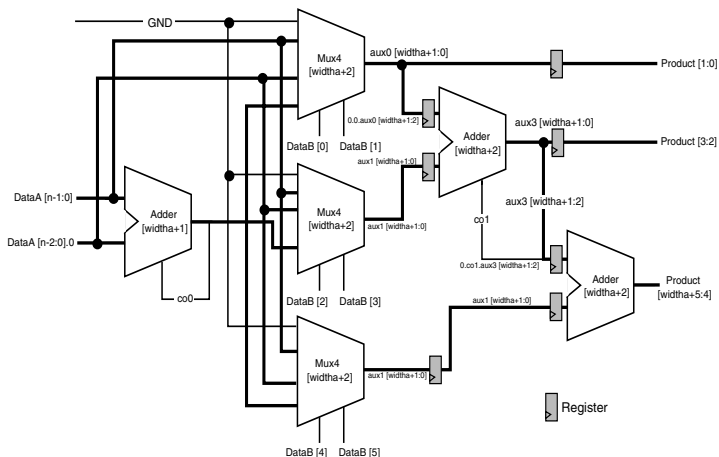

Figure 2-5. Booth Multiplier Architecture (Pipeline)

The number of pipeline stages is a function of the width of the DataB input. The number of logic levels per pipeline stage is a function of the width of the DataA input. Therefore, the number of logic levels per pipeline stage is equal to the number of logic levels of the first adder ( $WIDTHA + 1$ ) plus 1 for the 4 to 1 multiplexer, as shown in Figure 2-5.

*Table 2-46. Pipeline Stages as a Function of WidthB*

<b>WidthB Range</b>	<b>Pipeline Stages</b>
2	0
3-4	1
5-8	2
9-16	3

*Table 2-47. Logic Levels as a Function of WidthA*

<b>WidthA Range</b>	<b>Logic Levels</b>
2-5	3
6-17	4
18-30	5

---

*Comparators*

---

# Magnitude/Equality Comparator

## Features

- Parameterized word length
- Unsigned and signed (two's complement) data comparison
- One very fast gate level implementation
- Behavioral simulation model in VHDL and Verilog

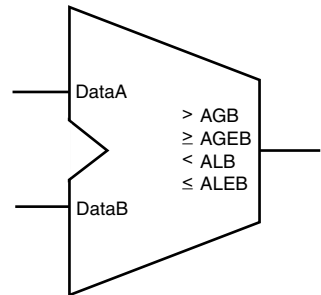

## Family Support<sup>1</sup>

ACT 1, ACT 2/1200XL, ACT 3, 3200DX, 40MX, 42MX, 54SX, 54SX-A, eX, 500K, PA

## Description

Table 3-1. Port Description

Port Name	Size	Type	Req/Opt	Function
DataA	WIDTH	Input	Req.	Input data
DataB	WIDTH	Input	Req.	Input data
AGB	1	Output	Opt.	Output comparison; $A > B$
AGEB	1	Output	Opt.	Output comparison; $A \geq B$
ALB	1	Output	Opt.	Output comparison; $A < B$
ALEB	1	Output	Opt.	Output comparison; $A \leq B$
AEB	1	Output	Opt.	Output comparison; $A = B$
ANEB	1	Output	Opt.	Output comparison; $A \neq B$

---

1. For ProASIC devices the Equality Comparator and the Magnitude Comparator are separate. For all other devices they are the same macro.



Table 3-2. Parameter Description

Parameter	Value	Function
WIDTH	2-32	Word length of DataA and DataB
REPRESENTATION	<b>UNSIGNED</b> SIGNED	
AGB_POLARITY	0 1 <b>2</b>	AGB polarity (active high, active low, and not used)
AGEB_POLARITY	0 1 <b>2</b>	AGEB polarity (active high, active low, and not used)
ALB_POLARITY	0 1 <b>2</b>	ALB polarity (active high, active low, and not used)
ALEB_POLARITY	0 1 <b>2</b>	ALEB polarity (active high, active low, and not used)
AEB_POLARITY	0 1 <b>2</b>	AEB polarity (active high, active low, and not used)
ANEB_POLARITY	0 1 <b>2</b>	ANEB polarity (active high, active low, and not used)

Table 3-3. Implementation Parameters

Parameter	Value	Description
LPMTYPE	LPM_COMPARE	Comparator category
LPM_HINT	COMPARE	Very fast carry select

Table 3-4. Parameter Rules

Parameter Rules
At least one of the comparisons (AGB, AGEB, ALB, ALEB, AEB or ANEB) must be selected

Table 3-4. Parameter Rules

Parameter Rules
Only one of the magnitude comparisons (AGB, AGEB, ALB or ALEB) can be selected at the same time
Only one of the equality comparisons (AEB or ANEB) can be selected at the same time

Table 3-5. Functional Description

DataA	DataB	AGB	AGEB	ALB	ALEB	AEB	ANEB
m	n	$m > n$	$m \geq n$	$m < n$	$m \leq n$	$m = n$	$m \neq n$

Table 3-6. Implementation Parameters

Implementation (LPM_HINT)	Description
COMPARE	Very fast carry select model

Table 3-7. Parameter Rules

Parameter rules
At least one of the comparisons (AGB, AGEB, ALB, ALEB, AEB or ANEB) must be selected
Only one of the magnitude comparisons (AGB, AGEB, ALB or ALEB) can be selected at the same time
Only one of the equality comparisons (AEB or ANEB) can be selected at the same time

# Constant Decoder

## Features

- Parameterized word length
- DEC/BIN/HEX radices for constant
- Equal/Not Equal comparison

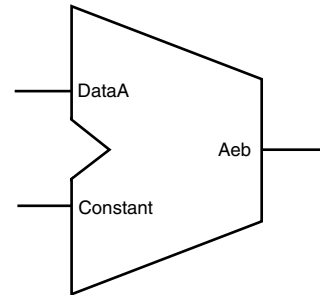

## Family Support

ACT 1, ACT 2/1200XL, ACT 3, 3200DX, 40MX, 42MX, 54SX, 54SX-A, eX, 500K, PA

## Description

*Table 3-8. Port Description*

Port Name	Size	Type	Req/Opt	Function
DataA	WIDTH	Input	Req.	Input Data
Aeb	1	Output	Req.	Result

*Table 3-9. Parameter Description*

Parameter	Value	Function
WIDTH	2-32 <sup>a</sup>	Word length of DataA and Constant
Radix	Dec/Bin/Hex	Base of Constant
Constant	Same as Width in selected Radix	The value with which input data will be compared
AEB_POLARITY	0, 1	A equals B polarity (Active High, Active Low)

a. For ProASIC, width is 2-128

*Table 3-10. Implementation Parameters*

<b>Parameter</b>	<b>Value</b>	<b>Description</b>
LPM_TYPE	LPM_COMPARE	Comparator category
LPM_HINT	WDEC	Very fast

Parameter Rules:

1. DataA is always binary and of the size of Width.
2. Constant must be of the selected Radix and be of the selected width for HEX/BIN.  
 e.g.: Radix: BIN, Width: 5, Constant: 00010  
 Radix Hex, Width:8, Constant: 0A

*Table 3-11. Functional Description*

<b>Aeb</b>
DataA = Constant

---

*Converters*

---

# Gray Counter

## Features

- Parameterized for Data Width
- Asynchronous Clear, Asynchronous Preset

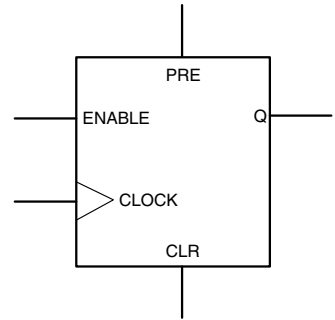

## Family support

54SX, Axcelerator

## Description

ACTgen can generate Gray Counters parameterized for a specified Data Width and with a choice of Enable, Asynchronous Clear, and Asynchronous Preset signals.

*Table 4-1. Port Description*

Port Name	Size	Type	Req/Opt	Function
Clock	WIDTH	Input	Req.	Input Data
Q	WIDTH	Output	Req.	Output Data
Clr	1	Input	Opt.	Clear
Pre	1	Input	Opt.	Preset
Enable	1	Input	Opt.	Enable

*Table 4-2. Parameter Description*

<b>Parameter</b>	<b>Value</b>	<b>Function</b>
GRAYCOUNT	2-99	Output Data Width
CLR_POLARITY	0,1,2	Clear Polarity
PRE_POLARITY	0,1,2	Preset Polarity
EN_POLARITY	0,1	Enable Polarity
CLK_EDGE	RISE,FALL	Clock Edge

*Table 4-3. Implementation Parameters*

<b>Parameter</b>	<b>Value</b>	<b>Function</b>
LPMTYPE	LPM_GRAY COUNTER	Gray Counter

---

# Binary to Gray / Gray to Binary

## Features

- Parameterized for Data Width

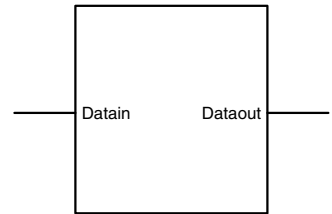

## Family support

54SX, Axcelerator

## Description

ACTgen can generate Binary to Gray and Gray to Binary Converters parameterized for a specified Data Width.

*Table 4-4. Port Description*

Port Name	Size	Type	Req/Opt	Function
Datain	WIDTH	Input	Req.	Input Data
Dataout	WIDTH	Output	Req.	Output Data

*Table 4-5. Parameter Description*

Parameter	Value	Function
GRAYDECODE/WIDTH	2-99	Input/Output Data Width

*Table 4-6. Implementation Parameters*

Parameter	Value	Function
LPMTYPE	LPM_GRAYENCODE/ LPMGRAYDECODE	Binary to Gray and Gray to Binary Converter



---

*Counters*

---

# Binary Counter

## Features

- Parameterized word length
- Up, Down and Up/Down architectures
- Asynchronous clear
- Synchronous counter load
- Synchronous count enable
- Terminal count flag
- Multiple gate level implementations (area/speed tradeoffs)
- Behavioral simulation model in VHDL and Verilog

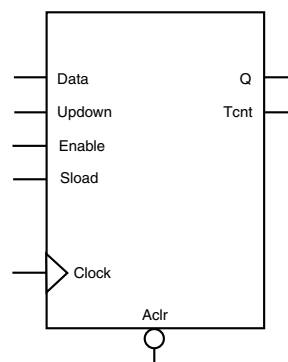

## Family Support

ACT 2/1200XL, ACT 3, 3200DX, 42MX, 54SX, 54SX-A, eX, 500K, PA

## Description

The ACTgen binary counters are general purpose UP, DOWN, or UP/DOWN (direction) counters.

When the count value equals  $2^{\text{width}}-1$ , the signal *Tcnt* (terminal count), if used, is asserted high.

The counters are WIDTH bits wide and have  $2^{\text{width}}$  states from “000...0” to “111...1”. The counters are clocked on the rising (RISE) or falling (FALL) edge of the clock signal *Clock* (CLK\_EDGE).

The *Clear* signal (CLR\_POLARITY), active low or high, provides an asynchronous reset of the counter to “000...0”. You may choose to not implement the reset function.

In the case of an Up/Down counter, the *Updown* signal controls whether the counter counts up (Updown = 1) or down (Updown = 0).

The counter could be loaded with *Data*. The *Sload* signal (LD\_POLARITY), active high or low, provides a synchronous load operation with respect to the clock signal *Clock*. You can choose to not implement this function.

The ACTgen counters have a count enable signal *Enable* (EN\_POLARITY). *Enable* can be active high or low. When *Enable* is not active, the counter is disabled and the internal state is unchanged.

*Table 5-1. Port Description*

Port Name	Size	Type	Req./Opt.	Function
Data	WIDTH	input	Opt.	Counter load input
Aclr	1	input	Opt.	Asynchronous counter reset
Enable	1	input	Req.	Counter enable
Sload	1	input	Opt.	Synchronous counter load
Clock	1	input	Req.	Clock
Updown	1	input	Opt.	UP (Updown = 1), DOWN (Updown = 0)
Q	WIDTH	out-put	Req.	Counter output bus
Tcnt	1	out-put	Opt.	Terminal count (active high)

*Table 5-2. Parameter Description*

Parameter	Value	Function
WIDTH	2-32	Word length of Data and Q
DIRECTION	UP DOWN UPDOWN	Counter direction
CLR_POLARITY	0 1 2	Aclr can be active low, active high or not used
EN_POLARITY	0 1	Enable can be active low, active high
LD_POLARITY	0 1 2	Sload can be active low, active high or not used
CLK_EDGE	RISE FALL	

Table 5-2. Parameter Description (Continued)

Parameter	Value	Function
TCNT_POLARITY	1 2	Tcnt can be active high or not used

Table 5-3. Fan-in Control Parameters

Parameter	Value
CLR_FANIN	<b>AUTO</b> MANUAL
CLR_VAL	<val> [default value for AUTO is 8, 1 for MANUAL]
LD_FANIN	<b>AUTO</b> MANUAL
LD_VAL	<val> [default value for AUTO is 6, 1 for MANUAL]
CLK_FANIN	AUTO <b>MANUAL</b>
CLK_VAL	<val> [default value for AUTO is 8, 1 for MANUAL]

Table 5-4. Implementation Parameters

Parameter	Value	Description	Family
LPMTYPE	LPM_COUNTER	Counter category	
LPM_HINT	LLCNT	Prescaled model	All
	TLACNT	Register look ahead model	All
	FBCNT	Fast Balanced model	54SX, 54SX-A
	BCNT	Balanced model	All
	LECNT	Fast Enable Balanced	All
	COMP CNT	Compact model	All
	RIPPLE	Ripple model	All

Table 5-5. Functional Description<sup>a</sup>

Data	Aclr	Enable	Sload	Clock	Up down	Qn+1	Tcnt n+1
X	0	X	X	X	X	0's	0
X	1	X	X	↑	X	Qn	$Q_{n+1} = 2^{\text{width}-1}$
X	1	0	0	↑	X	Qn	$Q_{n+1} = 2^{\text{width}-1}$
m	1	X	1	↑	X	m	$Q_{n+1} = 2^{\text{width}-1}$
X	1	1	0	↑	1	Qn + 1	$Q_{n+1} = 2^{\text{width}-1}$
X	1	1	0	↑	0	Qn - 1	$Q_{n+1} = 2^{\text{width}-1}$

a. Assume Aclr is active low, Enable is active high, Sload is active high, Clock is rising, Tcnt is active high

## Implementations

This section describes the implementation of the Pre-Scaled Counter, Register Look Ahead Counter, Fast Balanced Counter and the Balanced Counter.

### Pre-Scaled Counter

The pre-scaled counter achieves absolute maximum count and count enable performance by sacrificing synchronous load performance. This counter registers the two least significant bits and uses them as an enable for the upper bits. Count performance is limited only by the delay in the lower two bits and the enable path for the upper bits. Because the upper bits are only updated (enabled) every fourth cycle, they can accommodate more delay (up to one-fourth the clock frequency).

There are two limitations related to the use of the pre-scaled counter. The first is in analyzing the actual performance of the counter. The second is correctly performing data load functions; these two limitations are related. Two parameters must be measured to overcome these two limitations. The first parameter that must be measured is the worst internal delay inside the counter. The second parameter is the worst delay from Q0/Q1 to any upper bit. The minimum count period is then defined by the greater value of these two parameters.

The load function is a slave of the maximum internal path delay in the pre-scaled counter. The load function must be held for as many clock periods as required to exceed the maximum internal delay; this ensures that all internal nodes are settled and that correct count operation can be performed. This requirement can be waived if you can guarantee that 0's will always be loaded in Q0 and Q1 (resulting in only a single load cycle).

The count path in pre-scaled counters without Sload or Enable functions only have a single logic level for ACT 2/1200XL, ACT 3, 3200DX, 42MX 54SX, 54SX-A, and eX. All other combinations of pre-scaled counters have two logic levels in their count path. In these cases, given the two limitations mentioned previously related to the pre-scaled counter, use the Register Look Ahead or Fast Balanced counters.

### ***Register Look Ahead Counter***

This counter achieves the absolute maximum performance for the count, count enable, and synchronous load functions. The counter operates by registering intermediate count values providing "look-ahead" carry circuitry. As a result, this counter variation requires more flip-flops (sequential modules) than other counters.

### ***Fast Balanced Counter***

This counter is only available for the 54SX, 54SX-A, and eX families. It takes advantage of the architectural features of these families, including flip-flops with built-in enable and more powerful combinatorial cells. Using these two features, it is possible to build a very fast and compact binary counter without using "look-ahead" carry circuitry. This counter should be preferred over all the others available for this family.

### ***Balanced Counter***

This counter achieves high performance for both the count and enable functions using standard design approaches. Module count performance is sacrificed to maintain high speed. This counter is the result of the performance balance between the count/enable functions and the balance between the performance/cost in building this architecture. This counter should address most counter needs for the ACT 1, ACT 2/1200XL, ACT 3, 3200DX, 40MX and 42MX families.

### ***Fast Enable Counter***

This compact counter is fully synchronous and has higher performance than the ripple counter. However, this counter should only be used in moderate performance applications, especially for large widths.

### ***Ripple Counter***

The ripple counter is an asynchronous counter where the Q of each bit feeds the clock of the next bit; performance is sacrificed to build this variation. However, the ripple counter uses the least amount of logic resources. This counter should only be used in very low-performance applications or for very small counters.

Because of the asynchronous nature of the count function, this counter does not have a synchronous load function.

---

*Decoder*



# Decoder

## Features

- Parameterized output size (DECODES)
- Behavioral simulation model in VHDL and Verilog

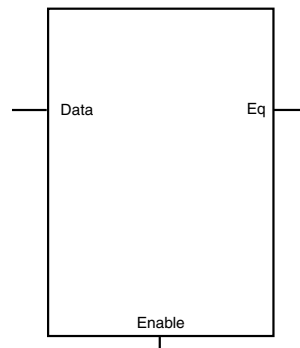

## Family Support

ACT 1, ACT 2/1200XL, ACT 3, 3200DX, 40 MX, 42MX, 54SX, 54SX-A, eX, 500K, PA

## Description

*Table 6-1. Port Description*

Port Name	Size	Type	Req/Opt	Function
Data	decln <sup>a</sup>	input	Req.	Input data
Enable	1	input	Opt.	Enable
Eq	DECODES	output	Req.	output

a. decln is an integer and  $\log_2(\text{DECODES}) = \text{decln}$  if  $\log_2(\text{DECODES} + 1) = \text{decln}$ . If decln is equal to 1, then Data is scalar, else Data is a bus.

*Table 6-2. Parameter Description*

Parameter	Value	Function
DECODES	2-32	Word length of Eq
EN_POLARITY	0 1 2	Enable polarity (active high, active low or not used)
EQ_POLARITY	0 1	Eq polarity (active low or active high)

Table 6-3. Functional Description<sup>a</sup>

<b>Data</b>	<b>Enable</b>	<b>Eq</b>
X	0	0's
m	1	dec <sup>b</sup> (m) == decodes-1 && <sup>c</sup> dec(m) == decodes-2 && ... && dec(m) == 0

- a. Assume enable is active low and Eq is active high.
- b. dec(m) defines the decimal value of m
- c. && indicates bity concatenation

---

*IOs*

---

# Input Buffers

## Features

- Parameterized for data width
- Choice of data buffers (Regular, Special, Pull-Up, Pull-Down)

## Family support

ACT2/1200XL, ACT3, 3200DX, 42MX, 54SX, 54SX-A, eX, 500K, PA, Axcelerator

## Description

ACTgen generates different types of Input Buffers with specified data width.

*Table 7-1. Port Description*

Port Name	Size	Type	Req/Opt	Function
PAD	WIDTH	Input	Req.	Input Data
PADP (LVDS and LVPECL, Axcelerator Only)	WIDTH	Input	Req.	Input Data for LVDS and LVPECL
PADN(LVDS and LVPECL, Axcelerator Only)	WIDTH	Input	Req.	Input Data for LVDS and LVPECL
Y	WIDTH	Output	Req.	Output Data

*Table 7-2. Parameter Description*

Parameter	Value	Function
WIDTH	1-99 (Limit may vary depending on the family)	Data Width

Table 7-2. Parameter Description (Continued)

Parameter	Value	Function
PULLUP (Proasic Only)	NO / YES	Choice of Pull-up version
VOLT (Proasic Only)	0,1,2	Choice of different voltage levels. 3.3v, 2.5v or 2.5v(Low Power)
TYPE (Axcelerator Only)	REG, LVCMOS25, LVCMOS18, LVCMOS15, PCI, PCIX, GTLP25, GTLP33, HSTL_I, HSTL_II, SSTL3_I, SSTL3_II, SSTL2_I, SSTL2_II, LVDS, LVPECL, LVCMOS25U, LVCMOS25D, LVCMOS18U, LVCMOS18D, LVCMOS15U, LVCMOS15D.	Type of Buffer

Table 7-3. Implementation Parameters

Parameter	Value	Description
LPM_TYPE	LPM_IO/ LPM_IB_IO (ProASIC)	Input Buffers
LPM_HINT	INBUF / IB (ProASIC)	Regular Input Buffers
	INBUF_SP (Axcelerator Only)	Special Input Buffers
	INBUF_PU (Axcelerator Only)	Pull-up Input Buffers
	INBUF_PD (Axcelerator Only)	Pull-down Input Buffers

---

# Output Buffers

## Features

- Parameterized for data width
- Choice of buffers (Regular, Special)

## Family support

ACT2/1200XL, ACT3, 3200DX, 42MX, 54SX, 54SX-A, eX, 500K, PA, Axcelerator

## Description

ACTgen generates different types of Output Buffers with specified data width.

*Table 7-4. Port Description*

Port Name	Size	Type	Req/Opt	Function
Data/A(Proasic)	WIDTH	Input	Req.	Input Data
PAD	WIDTH	Output	Req.	Output Data

*Table 7-5. Parameter Description*

Parameter	Value	Function
WIDTH	1-99 (Limit may vary depending on the family)	Data Width
VOLT (Proasic Only)	0,1,2,3,4,5	Choice of different voltage levels. 3.3v(PCI), 3.3v & Low Strength, 2.5v & High Strength, 2.5v & Low Strength, 2.5v(Low Power) & High Strength, or 2.5v(Low Power) & Low Strength

Table 7-5. Parameter Description (Continued)

Parameter	Value	Function
SLEW	0,1,2	Choice of different slew rates. Low, Normal or High
TYPE (Axcelerator Only)	REG, S_8, S_12, S_16, S_24, F_8, F_12, F_16, F_24, LVCOS25, LVCOS18, LVCOS15, PCI, PCIX, GTLP25, GTLP33, HSTL_I, HSTL_II, SSTL3_I, SSTL3_II, SSTL2_I, SSTL2_II, LVDS, LVPECL.	Type of Buffer Note : "S" in S_* denotes Low Slew Rate and "F" in F_* denotes High Slew Rate. Also 8,12,16,24 denote Output drive strengths of 1x, 2x, 3x, 4x respectively

Table 7-6. Implementation Parameters

Parameter	Value	Description
LPMTYPE	LPM_IO / LPM_OB_IO (Proasic)	Output Buffers
LPM_HINT	OUTBUF / OB (Proasic)	Regular Output Buffers
	OUTBUF_SP (Axcelerator Only)	Special Output Buffers

---

# Bi-Directional Buffers

## Features

- Parameterized for data width
- Choice of buffers (Regular, Special, Pull-up, Pull-down)

## Family support

ACT2/1200XL, ACT3, 3200DX, 42MX, 54SX, 54SX-A, eX, 500K, PA, Axcelerator

## Description

ACTgen generates different types of Input Buffers with specified data width.

*Table 7-7. Port Description*

<b>Port Name</b>	<b>Size</b>	<b>Type</b>	<b>Req/Opt</b>	<b>Function</b>
PAD	WIDTH	Inout	Req.	Inout Data
Data / A(Proasic)	WIDTH	Input	Req.	Input Data
Trien / ENABLE (Proasic)	1	Input	Req.	Enable
Y	WIDTH	Output	Req.	Output Data

*Table 7-8. Parameter Description*

<b>Parameter</b>	<b>Value</b>	<b>Function</b>
WIDTH	1-99 (Limit may vary depending on the family)	Data Width



Table 7-8. Parameter Description (Continued)

Parameter	Value	Function
VOLT (Proasic Only)	0,1,2,3,4,5	Choice of different voltage levels. 3.3v(PCI), 3.3v & Low Strength, 2.5v & High Strength, 2.5v & Low Strength, 2.5v(Low Power) & High Strength, or 2.5v(Low Power) & Low Strength
SLEW (Proasic Only)	0,1,2	Choice of the slew rates: Low, Normal, or High
PULLUP	NO / YES	Choice of Pull up version
TRIEN_POLARITY / EN_POLARITY (Proasic)	0,1	Enable Polarity
TYPE (Axcelerator Only)	REG, S_8, S_12, S_16, S_24, F_8, F_12, F_16, F_24, LVC MOS25, LVC MOS18, LVC MOS15, PCI, PCIX, GTLP25, GTLP33, S_8U, S_12U, S_16U, S_24U, F_8U, F_12U, F_16U, F_24U, S_8D, S_12D, S_16D, S_24D, F_8D, F_12D, F_16D, F_24D, LVC MOS25U, LVC MOS25D, LVC MOS18U, LVC MOS18D, LVC MOS15U, LVC MOS15D, HSTL_I, SSTL2_I, SSTL2_II, SSTL3_I, SSTL3_II	Type of Buffer. Note : "S" in S_* denotes Low Slew Rage and "F" in F_* denotes High Slew Rate. Also 8,12,16,24 denote Output drive strengths of 1x, 2x, 3x, 4x respectively

Table 7-9. Implementation Parameters

Parameter	Value	Function
LPMTYPE	LPM_IO / LPM_IOB_IO	Bi-directional Buffers

Table 7-9. Implementation Parameters (Continued)

Parameter	Value	Function
LPM_HINT	BIBUF / IOB, GLMIOB (Proasic)	Regular Bi-directional Buffers / IO pad with Global Connection, Two Multiplexed Pads & Global Connection (Proasic)
	BIBUF_SP(Axcelerator Only)	Special Bi-directional Buffers
	BIBUF_PU(Axcelerator Only)	Pull-up Bi-directional Buffers
	BIBUF_PD(Axcelerator Only)	Pull-down Bi-directional Buffers

---

# Tri-State Buffers

## Features

- Parameterized for data width
- Choice of buffers (Regular, Special, Pull-up, Pull-down)

## Family support

ACT2/1200XL, ACT3, 3200DX, 42MX, 54SX, 54SX-A, eX, 500K, PA, Axcelerator

## Description

ACTgen generates different types of Input Buffers with specified data width.

*Table 7-10. Port Description*

Port Name	Size	Type	Req/Opt	Function
PAD	WIDTH	Inout	Req.	Inout Data
Data / A (Proasic)	WIDTH	Input	Req.	Input Data
Trien / ENABLE (Proasic)	1	Input	Req.	Enable

*Table 7-11. Parameter Description*

Parameter	Value	Function
WIDTH	1-99 (Limit may vary depending on the family)	Data Width
VOLT (Proasic Only)	0,1,2,3,4,5	Choice of different voltage levels. 3.3v (PCI), 3.3v & Low Strength, 2.5v & High Strength, 2.5v & Low Strength, 2.5v (Low Power) & High Strength, or 2.5v (Low Power) & Low Strength

Table 7-11. Parameter Description (Continued)

Parameter	Value	Function
SLEW (Proasic Only)	0,1,2	Choice of the slew rates: Low, Normal, or High
TRIEN_POLARITY / EN_POLARITY (Proasic)	0,1	Enable Polarity
TYPE (Axcelerator Only)	REG, S_8, S_12, S_16, S_24, F_8, F_12, F_16, F_24, LVCMOS25, LVCMOS18, LVCMOS15, PCI, PCIX, GTLP25, GTLP33, S_8U, S_12U, S_16U, S_24U, F_8U, F_12U, F_16U, F_24U, S_8D, S_12D, S_16D, S_24D, F_8D, F_12D, F_16D, F_24D, LVCMOS25U, LVCMOS25D, LVCMOS18U, LVCMOS18D, LVCMOS15U, LVCMOS15D, HSTL_I, SSTL2_I, SSTL2_II, SSTL3_I, SSTL3_II	Type of Buffer. Note : "S" in S_* denotes Low Slew Rage and "F" in F_* denotes High Slew Rate. Also 8,12,16,24 denote Output drive strengths of 1x, 2x, 3x, 4x respectively

Table 7-12. Implementation Parameters

Parameter	Value	Function
LPMTYPE	LPM_IO / LPM_OB_IO	Tri-State buffers
LPM_HINT	TRIBUFF / OTB (Proasic)	Regular Tri-State Buffers
	TRIBUFF_SP (Axcelerator Only)	Special Tri-State Buffers
	TRIBUFF_PU (Axcelerator Only)	Pull-up Tri-State Buffers
	TRIBUFF_PD (Axcelerator Only)	Pull-down Tri-State Buffers

---

# Global Buffers

## Features

- Parameterized for data width
- Choice of buffers (Regular, Multiplexed, Internal Driver)

## Family support

500K, PA

## Description

ACTgen generates different types of Input Buffers with specified data width.

*Table 7-13. Port Description*

Port Name	Size	Type	Req/Opt	Function
PAD	WIDTH	Input	Req.	Inout Data
A	WIDTH	Input	Req.	Input Data
ENABLE	1	Input	Req.	Enable
GL	1	Output	Req.	Output Data
Y	WIDTH	Output	Req.	Output Data

*Table 7-14. Parameter Description*

Parameter	Value	Function
WIDTH	1-499 (Limit may vary depending on the type)	Data Width
VOLT	0,1,2	Choice of different voltage levels: 3.3V, 2.5V, 2.5V (Low Power)
PULLUP	NO / YES	Choice of Pull-up version

*Table 7-15. Implementation Parameters*

<b>Parameter</b>	<b>Value</b>	<b>Function</b>
LPMTYPE	LPM_GL_IO	All buffers
LPM_HINT	GL	Standard Global buffer
	GLIB	Standard Global buffer w/ an Input bufer
	GLMIB	Standard Global buffer with Multiplexed Input buffer
	GLINT	Global internal driver

---

# PECL Global Buffers

## Features

- Parameterized for data width
- Choice of buffers (Direct to Global, Multiplexed with Internal Signal)

## Family support

PA

## Description

ACTgen generates different types of Input Buffers with specified data width.

*Table 7-16. Port Description*

Port Name	Size	Type	Req/Opt	Function
PECLIN	WIDTH	Input	Req.	Input Data
PECLREF	WIDTH	Input	Req.	Reference Data
A	WIDTH	Input	Req.	Input Data
ENABLE	1	Input	Req.	Enable
GL	WIDTH	Output	Req.	Output Data
Y	WIDTH	Output	Req.	Output Data

*Table 7-17. Parameter Description*

Parameter	Value	Function
WIDTH	1-2	Data Width

*Table 7-18. Implementation Parameters*

<b>Parameter</b>	<b>Value</b>	<b>Function</b>
LPM_TYPE	LPM_GLPE_IO	PECL Global buffers
LPM_HINT	GLPE	Direct to Global
	GLPEMIB	Multiplexed with Internal Signal



---

# PerPin FIFO

## Features

- Parameterized for Data Width and almost Full/Empty Values.
- Choice of generating with Input or Output pads
- Choice of generating with or without a Controller
- Choice of Dedicated or Core Logic controller
- Asynchronous, or synchronous write
- Rising edge triggered or level sensitive
- Supported netlist formats: VHDL and Verilog

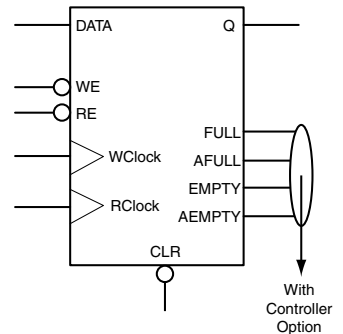

## Family support

Axcelerator

## Description

ACTgen can generate Input or Output PerPin FIFOs with or without a Controller parameterized depending on the 'Width' parameter.

When generating PerPin FIFOs with a Controller, you can specify almost full (AfVal) and almost empty (AeVal) values in the GUI. You can choose two types of controllers: either an Embedded PerPin FIFO controller or one that is generated using core logic.

The maximum number of PerPin FIFOs that a single Embedded controller can control is 26. ACTgen restricts generation of PerPin FIFOs with Embedded Controllers to a Max. Width of 26. The number of PerPin FIFOs that can be controlled using the core logic controller depends entirely on the available resources and PerPin FIFOs in the chip, hence there is no restriction on the core logic controller option. AeVal and AfVal accept any value between 1 and 63.

An I/O FIFO Embedded controller can support upto 26 PerPin FIFOs depending on the die size and the location of the PerPin FIFO on the die.

Please note that if more than 26 PerPin FIFOs are to be used, there will be 2 separate set of flags from each Embedded PerPin FIFO controller.

*Table 7-19. Port Description*

<b>Port Name</b>	<b>Size</b>	<b>Type</b>	<b>Req/Opt</b>	<b>Function</b>
DATA	WIDTH	Input	Req.	Input Data
Q	WIDTH	Output	Req.	Output Data
WE	1	Input	Req.	Write Enable
RE	1	Input	Req.	Read Enable
Rclock	1	Input	Req.	Read Clock
WClock	1	Input	Req.	Write Clock
CLR	1	Input	Req.	Clear Signal
FULL	1	Output	Opt.	Full Flag
AFULL	1	Output	Opt.	Almost Full Flag
EMPTY	1	Output	Opt.	Empty Flag
AEMPTY	1	Output	Opt.	Almost Empty Flag

*Table 7-20. Parameter Description*

<b>Parameter</b>	<b>Value</b>	<b>Function</b>
WIDTH	2-26	Data Width with Dedicated Controller
	1-128	Data Width without a Controller or with Core Logic Controller
AEVAL	0-62	For Almost Empty Value Flag
AFVAL	1-63	For Almost Full Value Flag

Table 7-20. Parameter Description (Continued)

Parameter	Value	Function
CTL	0,1	Dedicated or Core Logic Controller
PORT*	<Port Names>	Optional - Can be used if port name needs to be changed

Table 7-21. Implementation Parameters

Parameter	Value	Function
LPMTYPE	LPM_IOFIFO_I_NC	Input IOFIFO with no Controller
	LPM_IOFIFO_O_NC	Output IOFIFO with no Controller
	LPM_IOFIFO_I_C	Input IOFIFO with Controller
	LPM_IOFIFO_O_C	Output IOFIFO with Controller
LPM_HINT	IR, ISP, IPU, IPD, ILV	Input IOFIFO - With Regular, Special, Pull up, Pull down input buffers
	OR_NC, OSP_NC, OLV_NC	Output IOFIFO - With Regular, Special, LVDS/LVPECL output buffers
	IR_C, ISP_C, IPU_C, IPD_C, ILV_C	Input IOFIFO - With Regular, Special, Pull up, Pull down input buffers
	OR_C, OSP_C, OLV_C	Output IOFIFO - With Regular, Special, LVDS/LVPECL output buffers

---

# Dual Data Rate Register

## Features

- Parameterized for Data Width and almost Full/Empty Values
- Choice of Input buffers

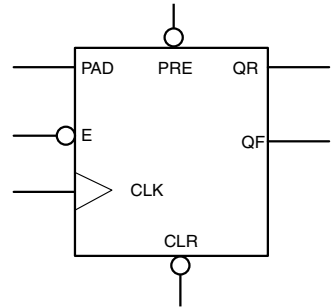

## Family support

Axcelerator

## Description

ACTgen can generate Dual Data Rate Registers parameterized for a specific Data Width and with a choice of the type of Input Buffers.

*Table 7-22. Port Description*

Port Name	Size	Type	Req/Opt	Function
PAD	WIDTH	Input	Req.	Input Data
QR	WIDTH	Output	Req.	Output Data
QF	WIDTH	Output	Req.	Ouput Data
E	1	Input	Req.	Enable
CLK	1	Input	Req.	Clock
CLR	1	Input	Req.	Clear
PRE	1	Output	Req.	Preset

Table 7-23. Parameter Description

Parameter	Value	Function
WIDTH	1-128	Data Width
DDR	0,1	0 for DDR Register and 1 for DDR FIFO

Table 7-24. Implementation Parameters

Parameter	Value	Function
LPM_TYPE	LPM_DDR	DDR Register / FIFO category
LPM_HINT	DDR	DDR Register with Regular Input buffers
	DDR_SP	DDR Register with Special Input buffers
	DDR_PU	DDR Register with Pull-up Input buffers
	DDR_PD	DDR Register with Pull-down Input buffers

# Dual Data Rate FIFO

## Features

- Parameterized for Data Width
- Choice of Input buffers

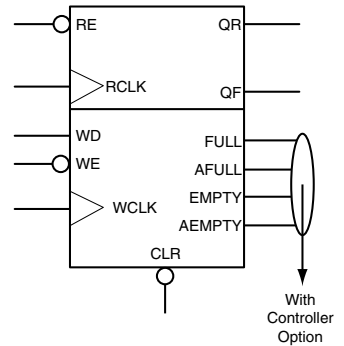

## Family support

Axcelerator

## Description

ACTgen can generate Dual Data Rate FIFOs parameterized for specified Data Width and with a choice of Input Buffers.

Table 7-25. Port Description

Port Name	Size	Type	Req/Opt	Function
PAD	WIDTH	Input	Req.	Input Data
QR	WIDTH	Output	Req.	Output Data
QF	WIDTH	Output	Req.	Output Data
REN	1	Input	Req.	Read Enable
WEN	1	Input	Req.	Write Enable
RCLK	1	Input	Req.	Read Clock
WCLK	1	Input	Req.	Write Clock
CLR	1	Input	Req.	Clear
FULL	1	Input	Opt.	Full Flag
AFULL	1	Input	Opt.	Almost Full Flag
EMPTY	1	Input	Opt.	Empty Flag

Table 7-25. Port Description (Continued)

Port Name	Size	Type	Req/Opt	Function
AEMPTY	1	Input	Req.	Almost Empty Flag

Table 7-26. Parameter Description

Parameter	Value	Function
WIDTH	2-26	Data Width with Dedicated Controller
	1-128	Data Width without a Controller or with Core Logic Controller
AEVAL	1-63	For Almost Empty Value Flag
AFVAL	1-63	For Almost Full Value Flag
CTL	0,1	Dedicated or Core Logic Controller
DDR	1	1 for DDR FIFO

Table 7-27. Implementation Parameters

Parameter	Value	Function
LPMTYPE	LPM_DDR	DDR FIFO category
LPM_HINT	DDRF/DDR	DDR FIFO with Regular Input buffers; note that the 'F' denotes 'with controller'
	DDRF_SP/DDR_SP	DDR_FIFO with Special Input buffers
	DDRF_PU/DDR_PU	DDR FIFO with Pull-up Input buffers
	DDRF_PD/DDR_PD	DDR FIFO with Pull-down Input buffers

---

*Logic*



---

# Logic (AND)

## Features

- Parameterized AND size
- Behavioral simulation model in VHDL and Verilog

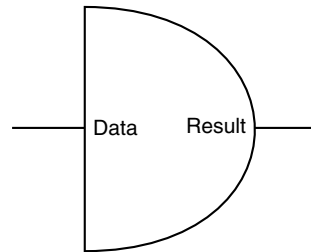

## Family Support

ACT 1, ACT 2/1200XL, ACT 3, 3200DX, 40MX, 42MX, 54SX, 54SX-A, eX, 500K, PA

## Description

*Table 8-1. Port Description*

Port Name	Size	Type	Req/Opt	Function
Data	SIZE	input	Req.	Input data
Result	1	output	Req.	output

*Table 8-2. Parameter Description*

Parameter	Value	Function
SIZE	2-64	Word length of data
RESULT_POLARITY	0 <b>1</b>	Output polarity (active low or active high)

*Table 8-3. Functional Description<sup>a</sup>*

Data	Result
m	m[0] and m[1] and ... and m[SIZE-1]

a. result is active; highresult is active high

# Logic (OR)

## Features

- Parameterized OR size
- Behavioral simulation model in VHDL and Verilog

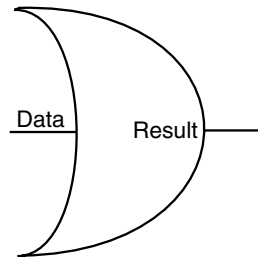

## Family Support

ACT 1, ACT 2/1200XL, ACT 3, 3200DX, 40MX, 42MX, 54SX, 54SX-A, eX, 500K, PA

## Description

*Table 8-4. Port Description*

Port Name	Size	Type	Req/Opt	Function
Data	SIZE	input	Req.	input data
Result	1	output	Req.	output

*Table 8-5. Parameter Description*

Parameter	Value	Function
SIZE	2-64	Word length of data
RESULT_POLARITY	0 <b>1</b>	Output polarity (active low or active high)

*Table 8-6. Functional Description<sup>a</sup>*

Data	Result
m	m[0] or m[1] or ... or m[SIZE-1]

a. result is active high

# Logic (XOR)

## Features

- Parameterized XOR size
- Behavioral simulation model in VHDL and Verilog

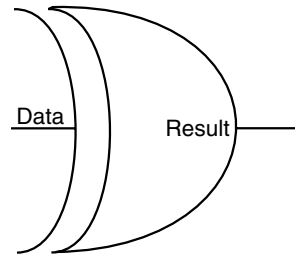

## Family Support

ACT 1, ACT 2/1200XL, ACT 3, 3200DX, 40MX, 42MX, 54SX, 54SX-A, eX, 500K, PA

## Description

Table 8-7. Port Description

Port Name	Size	Type	Req/Opt	Function
Data	SIZE	input	Req.	input data
Result	1	output	Req.	output

Table 8-8. Parameter Description

Parameter	Value	Function
SIZE	2-64	Word length of data
RESULT_POLARITY	0 <b>1</b>	Output polarity (active low or active high)

Table 8-9. Functional Description<sup>a</sup>

Data	Result
m	m[0] xor m[1] xor ... xor m[SIZE-1]

a. result is active high

---

# *Multiplexer*

# Multiplexer

## Features

- Parameterized word length
- Parameterized multiplexer input number
- Behavioral simulation model in VHDL and Verilog

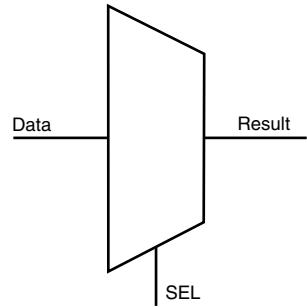

## Family Support

ACT 1, ACT 2/1200XL, ACT 3, 3200DX, 40MX, 42MX, 54SX, 54SX-A, eX, 500K, PA

## Description

Table 9-1. Port Description

Port Name	Size	Type	Req/Opt	Function
Data <sub>0</sub>	WIDTH	Input	Req.	Input data
Data <sub>1</sub>	WIDTH	Input	Req.	Input data
...	...	...	...	...
Data <sub>SIZE-1</sub>	WIDTH	Input	Req.	Input data
SEL <sub>0</sub>	1	Input	Req.	Select line
SEL <sub>1</sub>	1	Input	Req.	Select line
...	...	...	...	...
SEL <sub>SIZELN-1</sub>	1	Input	Req.	Select line
Result	WIDTH	Output	Req.	output

Table 9-2. Parameter Description

Parameter	Value	Function
WIDTH	2-32	Word length of Data
SIZE	1-32	Number of data inputs

*Table 9-3. Functional Description*

<b>Data<sub>0</sub></b>	<b>Data<sub>1</sub></b>	<b>...</b>	<b>Data<sub>SIZE-1</sub></b>	<b>Sel<sub>0</sub></b>	<b>Sel<sub>1</sub></b>	<b>...</b>	<b>Sel<sub>SIZELN-1</sub></b>	<b>Result</b>
m <sub>0</sub>	m <sub>1</sub>	...	m <sub>SIZE-1</sub>	0	0	...	0	m <sub>0</sub>
m <sub>0</sub>	m <sub>1</sub>	...	m <sub>SIZE-1</sub>	1	0	...	0	m <sub>1</sub>
...	...	...	...	...	...	...	...	...
m <sub>0</sub>	m <sub>1</sub>	...	m <sub>SIZE-1</sub>	1	1	...	1	m <sub>SIZE-1</sub>

---

## *Minicores*

---

# FIR Filter

## Features

- Variable input data width:  
2 to 16 bit input data
- Variable output data width:  
3 to 64 bit output data
- Support for up to 64 taps
- Support of symmetric coefficients
- Optional IO insertion
- Optional registers for filter in-  
and output
- Verilog RTL model for simulation
- VHDL RTL model for synthesis<sup>1</sup>

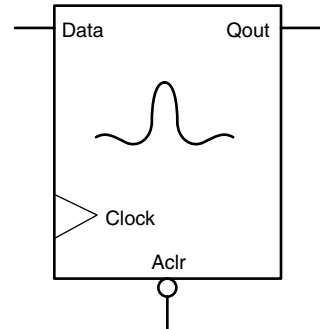

## Family support

54SX, 54SX-A, 500K, PA, Axcelerate

## Design Flow

An overview of the design flow required for the FIR filter is shown in Figure 10-1.

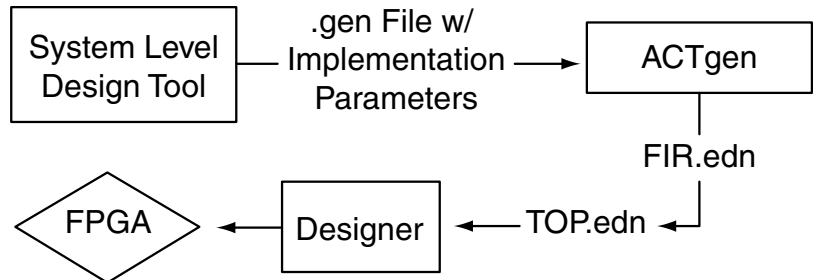

Figure 10-1. FIR Filter Design Flow

---

1. Synthesized filter designs are usually slower, but more compact.



Generate the filter coefficients and other implementation parameters using a system level design tool (like Matlab). This information is made available for ACTgen in form of a <design>.gen file. .

From that point on it follows the regular design flow as described in the Actel *Getting Started User's Guide*.

## Description

The ACTgen FIR-filter macro supports symmetric, high-speed, parallel FIR-filters with up to 64 time taps.

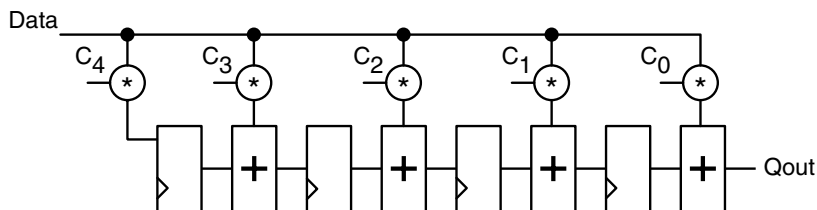

*Figure 10-2. Tap Transposed from FIR Filter*

The architecture is a variation of the "transposed form" of the FIR-filter as shown in Figure 10-2, making use of ACTgen's signed Constant Multiplier. The data is assumed to be signed. Data- and coefficient widths are the same (D\_WIDTH).

Figure 10-2 suggests that coefficients with a value of 0 are desirable for this type of architecture, since they will not generate any multiplication hardware. "Halfband" filters are trying to maximize the number of 0-coefficients and might result in significant area savings over regular filters of the same order .

Table 10-1. Port Description

Port Name	Size	Type	Req/Opt?	Function
Data	D_WIDTH	input	Req.	Input Data
Clock	1	input	Req.	Filter clock
Aclr	1	input	Opt.	Asynchronous Clear
Qout	O_WIDTH	input	Req.	Filter output = $\sum \chi_i * \delta t$

Table 10-2. Parameter Description

Parameter	Value	Function
D_WIDTH	3 .. 16	Input Data Width
O_WIDTH	3 .. 64	Output Data Width
TAPS	3 .. 64	Number of time taps
CLK_EDGE	<b>RISE</b> FALL	Clock sensitivity
CLR_POLA	2 0 1	None, active high, active low
PREC		Internal precision
INSERT_PAD	<b>NO</b> YES	Pad insertion
INSERT_IOREG	<b>NO</b> YES	Register inputs and outputs
C1 ... C32	0 .. 2C_WIDTH	2's complement coefficients (integers)

The output width O\_WIDTH has no impact on the filter size. Internally, ACTgen always uses the maximum precision filter, unless specified otherwise using the internal precision parameter PREC. If you set O\_WIDTH to 0, ACTgen use the maximum output resolution (MAX\_RES). For values of O\_WIDTH greater than MAX\_RES the result is sign-extended. For values of

O\_WIDTH smaller than MAX\_RES ACTgen cuts some of the lower bits. An upper estimate for MAX\_RES is

$$\text{MAX\_RES} \leq \text{D\_WIDTH} + \lceil \log_2(\text{TAPS}) \rceil$$

For example a 12-tap filter with 8-bit data and coefficients might yield up to  $(8 + 8 + 4)$  bit = 20 bit output resolution.

The coefficients C1 to C16 are positive integers, which will be interpreted as two's complement numbers. That means 0 to  $2^{C\_WIDTH-1}-1$  are considered positive, and  $2^{C\_WIDTH-1}$  to  $2^{C\_WIDTH}-1$  will be interpreted as negative numbers.

Only unique coefficients need to be specified properly, all other coefficients need to be set to any value, e.g. "0". An N-tap filter requires  $(N / 2) + (N \% 2)$  unique coefficients.

Only unique coefficients need to be specified properly, all other coefficients need to be set to any value, e.g. "0". An N-tap filter requires  $(N / 2) + (N \% 2)$  unique coefficients.

*Table 10-3. Parameter Rules*

Family	Variation	Parameter rules
All	FIR2	PREC >= O_WIDTH
54SX, 54SX-A	All	O_WIDTH <= 32
54SX, 54SX-A	All	TAPS <= 32

*Table 10-4. Implementation Parameters*

Parameter	Value	Description
LPMTYPE	LPM_FIR	FIR-filter category
LPM_HINT	FIR1	Basic Options
	FIR2	Advanced Options

*Table 10-5. Internal Precision (PREC)*

<b>Variation</b>	<b>Value</b>	<b>Description</b>
Basic Options	<b>97, 0</b>	Maximum output resolution, same as O_WIDTH
Advanced Options	PREC	See parameter rules

Internal Precision (PREC) specifies the minimum number of bits

- For the time tab registers
- From multiplier outputs kept for further processing
- From adder outputs kept for further processing

Currently the RTL-model does not reflect the PREC parameter, so there may be differences between the simulated output of the structural netlist and the RTL-model for the low-order bits.

---

# CRC Minicore

## Features

- General-purpose cyclic redundancy Code generator
- Fully synchronous, single clock operation (over 100 MHz for many configurations)
- Parameterized arbitrary polynomial (from 1 up to 64-bit)
- Parameterized data input width
- Parameterized register initialization
- Parameterized bit and byte ordering
- Parameterized bit pattern for CRC output XOR with

## Family support

SX, Axcelerator

## Description

CRC Minicore is a universal Cyclic Redundancy Check (CRC) Polynomial generator that validates data frames and ensures data integrity during data transmission.

To meet different application requirements, CRC minicore provides many different configuration parameters. These parameters include Data Width, Register Initialization, and CRC output data characteristics.

- Data width specifies the number of bits upon which CRC Minicore generates the CRC value in a single clock cycle. For example, 8 bit data width CRC32 performs CRC calculations on 8 bit per clock.
- Register Initialization provides the seed value for CRC generation.
- CRC data characteristics parameters provide designers great flexibility of CRC data characteristics.

Thus, the parameter of CRC output XOR bit pattern controls how the CRC value is inverted before it is injected into the data stream. Although CRC Minicore generator (ACTgen) provides seven commonly used CRC polynomials, it does provide polynomial

parameters (size and value) for any other generic CRC creation. The polynomial size can span from 1-bit to 64-bit.

*Table 10-6. XOROUT Configuration*

<b>XOROUT</b>	<b>Description</b>
1	All bits are not inverted (00000000) xor CRC
2	All bits are inverted (..FFFFFF) xor CRC
3	Even bits are inverted, odd bits are not inverted (...10101010) xor CRC
4	Odd bits are inverted, even bits are not inverted (...01010101) xor CRC

*Table 10-7. CRC Operation Control*

<b>rst_n</b>	<b>init_n</b>	<b>enable</b>	<b>Description</b>
0	x	x	A synchronous reset, set to initial register value
1	0	x	Synchronous initialize
1	1	0	Disable, register maintain the current value
1	1	1	Generate CRC on the input data

*Table 10-8. Port Description*

<b>Port Name</b>	<b>width</b>	<b>Description</b>
CLK	1	Clock port
rst_n	1	Asynchronous reset
init_n	1	Synchronous load CRC value
enable	1	CRC enable/disable control

Table 10-8. Port Description (Continued)

Port Name	width	Description
data_in	Data_width	Input data word
CRC_in	Poly_size	CRC value to be load in
CRC_out	Poly_size	Generated CRC value

Table 10-9. Parameter Description

Name	Poly_width	Poly_value	initial	xorout
CRC32	32	04C11DB7	FFFF..	2 (FFFFFFF...)
CCIT CRC16	16	1021	FFFF....	2 (FFFFFFF...)
ATM CRC8	8	7	FFFF....	2 (FFFFFFF...)
kermit	16	8408	000000...	1 (00000000)

---

*PLLs*



---

# PLL for ProASIC<sup>PLUS</sup>

You can use ACTgen to configure PLLs according to your needs, and generate a netlist that has a PLL primitive instantiated with the correct specified configuration

## Features

- Clock Delay Adjustment
- Clock Frequency Synthesis
- Clock Phase Shifting

## Family support

PA

## Description

Summary of the menu items available when you generate a PLL for ProASIC<sup>PLUS</sup>.

**Configuration** - Dynamic or Static Configuration

**Input Clock Frequency** - Floating point value between 6.0 and 240 MHz

**Primary Clock Frequency** - Floating point value between 6.0 and 240 MHz. If the specified frequency cannot be achieved, the closest approximate frequency will be provided.

**Bypass PLL in Primary Clock** - Selecting this checkbox bypasses the PLL for the primary clock. When the PLL is bypassed, the primary clock frequency must be equal to or be 1/2, 1/3 or 1/4 of input frequency.

**Primary Clock Phase Shift** - Supports 4 values 0, 90, 180, 270 degrees. Not valid when PLL is bypassed for primary clock.

**Primary Clock Delay** - This is a floating point between -4.0 and 8.0 with increments of 0.25. When PLL is bypassed for primary clock, only 0, 0.25, 0.5 and 4 ns are valid delays.

**Secondary Clock Input Frequency** - Floating point value between 1.5 and 240 MHz. This is valid only when secondary clock is selected and PLL is bypassed.

**Secondary Clock output Frequency** - Floating point value between 1.5 and 240 MHz. This is valid only when secondary clock is selected. If the

specified value cannot be achieved, the closest approximate frequency will be provided.

**Bypass PLL in Secondary clock** - Selecting this checkbox bypasses the PLL for secondary clock. When the PLL is bypassed, the secondary clock frequency must be equal to or be 1/2, 1/3 or 1/4 of secondary input frequency.

**Secondary Clock Delay** - This is a floating point between -4.0 and 8.0 with increments of 0.25. When PLL is bypassed for secondary clock, only 0, 0.25, 0.5 and 4 ns are the valid delays.

**Feedback** - A radio button to select between Internal, External and Deskewed feedback.

*Table 11-1. Port Description*

Name	Size	Type	Req/Opt	Function
GLA	1	Output	Opt	Secondary clock output
GLA	1	Output	Req	Primary clock output
LOCK	1	Output	Req	PLL Lock
SDOUT	1	Output	Req	Output of serial interface shift register
CLK	1	Input	Req	Input clock for primary clock
CLKA	1	Input	Opt	Input clock for secondary clock. Valid only in Bypass Mode
EXTFB	1	Input	Opt	External Feedback
SCLK	1	Input	Opt	Shift Clock (Only Dynamic Mode)
SSHIFT	1	Input	Opt	Serial Shift enable (Only Dynamic Mode)
SDIN	1	Input	Opt	Serial Data in for PLL configuration bits (Only Dynamic Mode)
SUPDATE	1	Input	Opt	Serial Update (Only Dynamic Mode)
MODE	1	Output	Opt	Dynamic or Static mode indicator

---

# Axcelerator PLL

## Features

- Clock Delay Minimization
- Clock Delay Adjustment
- Clock Frequency Synthesis
- Programmable delay lines for clock delay adjustment
- 6-bit divider in the feedback path for clock multiplication
- 6-bit divider in one of the output paths for clock division
- Cascadable up to 2 PLLs

## Family support

Axcelerator

## Description

The Axcelerator PLL has three main features. They are:

- Clock Delay Minimization

In this mode the PLL can perform either a positive or negative clock delay operation of up to 3.75ns in increments of 250ps before or after the clock edge of the incoming reference clock. The value of the delay is programmable via the five bits of the DelayLine bus.

- Clock Delay Adjustment

There are two delay elements that serve to adjust the delay of the output clock signal.

- Clock Frequency Synthesis

The multiplier and divider can be used together to synthesize a wide range of output frequencies from the reference clock. Input frequencies are allowed to be in the range of 14 MHz to 200 MHz. Multiplication and division factors are integers in the range of 1 to 64. The maximum allowable output frequency is 1 GHz. The output duty cycle is fixed at 50/50.

## Cascading Blocks

The device supports cascading of up to 2 PLLs.

*Table 11-2. Port Description*

Name	Size	Type	Req/Opt	Function
RefClk	1	Input	Req	Refclk
PWRDN	1	Input	Req	Power Down
Lock	1	Output	Req	PLL Lock
FB	1	Input	Opt	Feedback (only external feedback)
CLK(freq)	1	Output	Opt	Clk1 with the required freq
CLK(freq)	1	Output	Opt	CLK2 with the required freq
CLK(freq)	1	Output	Opt	Clk1 of 2nd PLL with the intermediate Freq (only in cascaded mode)
CLK(freq)	1	Output	Opt	CLK2 with the intermediate freq (only in cascaded mode)

*Table 11-3. Parameter Description*

Parameter	Value	Function
FB	<b>Internal</b> External	Feedback
IFREQ	14.0 - 200.0 MHz	Input Frequency
PFREQ	14.0 - 1000.0	Primary Clock freq
SFREQ	14.0 - 1000.0	Secondary Clock freq

---

## *Register (Storage Elements)*

# Storage Register

## Features

- Parameterized word length
- Asynchronous clear
- Synchronous register parallel load
- Behavioral simulation model in VHDL and Verilog

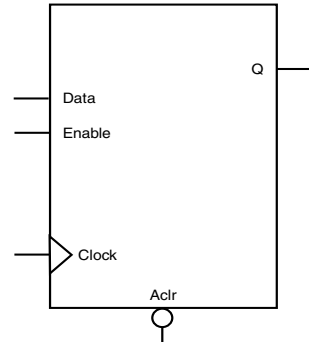

## Family Support

ACT 1, ACT 2/1200XL, ACT 3, 3200DX, 40MX, 42MX, 54SX, 54SX-A, eX, 500K, PA, Axcelerator

## Description

Storage registers have a parallel-in/parallel-out (PIPO) architecture. The registers are WIDTH bits. They are clocked on the rising (RISE) or falling (FALL) edge of the clock *Clock* (CLK\_EDGE).

The *Clear* signal (CLR\_POLARITY), active high or low, provides an asynchronous reset of the registers to “000...0”. You may choose to not implement the reset function.

The *Enable* signal (EN\_POLARITY), active high or low, provides a synchronous load enable operation with respect to the *Clock* signal. You can choose to not implement this function. Storage registers are then loaded with a new value every clock cycle.

Table 12-1. Port Description

Port Name	Size	Type	Req./Opt.	Function
Data	WIDTH	input	Req.	Register load input
Aclr	1	input	Opt.	Asynchronous register reset
Enable	1	input	Opt.	Synchronous Parallel load enable
Clock	1	input	Req.	Clock
Q	WIDTH	output	Req.	Register output bus

Table 12-2. Parameter Description

Parameter	Family	Value	Function
WIDTH	500K, PA	1-512	Word length of Data and Q
	All other	1-99	
CLR_POLARITY	ALL	<b>0 1 2</b>	Aclr can be active low, active high or not used
EN_POLARITY	ALL	<b>0 1 2</b>	Enable can be active low, active high
CLK_EDGE	ALL	<b>RISE FALL</b>	Clock can be rising or falling

Table 12-3. Fan-in Control Parameters

Parameter	Value
CLR_FANIN	<b>AUTO</b> MANUAL
CLR_VAL	<val> [default value for AUTO is 8, 1 for MANUAL]
EN_FANIN	<b>AUTO</b> MANUAL
EN_VAL	<val> [default value for AUTO is 6, 1 for MANUAL]
CLK_FANIN	AUTO <b>MANUAL</b>
CLK_VAL	<val> [default value for AUTO is 8, 1 for MANUAL]

Table 12-4. Implementation Parameters

Parameter	Value	Description
LPM_TYPE	LPM_DFF	Register category
LPM_HINT	PIPO	Parallel-in/Parallel-out

*Table 12-5. Functional Description<sup>a</sup>*

<b>Data</b>	<b>Aclr</b>	<b>Enable</b>	<b>Clock</b>	<b>Q</b>
X	0	X	X	0's
X	1	X	↓	$Q_n$
X	1	0	↑	$Q_n$
m	1	1	↑	$Q_{n+1} = m$

a. Assume Aclr is active low, Enable is active high, Clock is rising (edge-triggered)



# Shift Register

## Features

- Parameterized word length
- Asynchronous clear
- Synchronous parallel load
- Behavioral simulation model in VHDL and Verilog

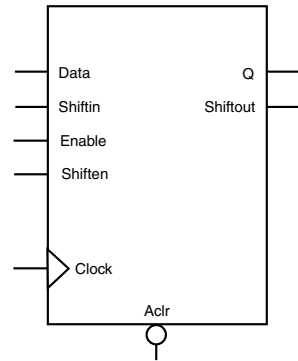

## Family Support

ACT 1, ACT 2/1200XL, ACT 3, 3200DX, 40MX, 42MX, 54SX, 54SX-A, eX, 500K, PA, Axcelerator

## Description

Shift registers have parallel-in/parallel-out (PIPO), parallel-in/serial-out (PISO), serial-in/parallel-out (SIPO) and serial-in/serial-out (SISO) architecture. The registers are WIDTH bits. They are clocked on the rising (RISE) or falling (FALL) edge of the clock *Clock* signal (CLK\_EDGE).

The *Clear* signal (CLR\_POLARITY), active high or low, provides an asynchronous reset of the registers to “000...0”. You may choose to not implement the reset function.

Shift registers can be loaded with *Data*. The *Enable* signal (EN\_POLARITY), active high or low, provides a synchronous load enable operation with respect to the clock signal *Clock*. You may choose to not implement this function. Shift registers are then implemented in a serial-in mode (SIPO or SISO).

Shift registers have a shift enable signal *Shiften* (SHEN\_POLARITY) that can be active high or low. When *Shiften* is active, the register is shifted internally. The LSB is loaded with *Shiftin*.

In the current implementation, *Enable* has priority over *Shiften*.

Table 12-6. Port Description

Port Name	Size	Type	Req/Opt	Function
Data	WIDTH	input	Opt.	Register load input data
Shiftin	1	Input	Opt.	Shift in signal

Table 12-6. Port Description (Continued)

Port Name	Size	Type	Req/Opt	Function
Aclr	1	input	Opt.	Asynchronous register reset
Enable	1	input	Opt.	Synchronous parallel load enable
Shiften	1	input	Req.	Synchronous register shift enable
Clock	1	input	Req.	Clock
Q	WIDTH	output	Opt.	Register output bus
Shiftout	1	output	Opt.	Serial output

Table 12-7. Parameter Description

Parameter	Family	Value	Function
WIDTH	500K, PA	2-512	Word length of Data and Q
	All other	2-99	
CLR_POLARITY	ALL	0 1 2	Aclr can be active low, active high or not used
EN_POLARITY	ALL	0 1 2	Enable can be active low, active high
SHEN_POLARITY	ALL	0 1	Shiften can be active low, active high or not used
CLK_EDGE	ALL	RISE FALL	Clock can be rising or falling

Table 12-8. Fan-in Control Parameters

Parameter	Value
CLR_FANIN	<b>AUTO</b> MANUAL
CLR_VAL	<val> [default value for AUTO is 8, 1 for MANUAL]
EN_FANIN	<b>AUTO</b> MANUAL
EN_VAL	<val> [default value for AUTO is 6, 1 for MANUAL]
SHEN_FANIN	<b>AUTO</b> MANUAL

Table 12-8. Fan-in Control Parameters (Continued)

Parameter	Value
SHEN_VAL	<val> [default value for AUTO is 6, 1 for MANUAL]
CLK_FANIN	AUTO <b>MANUAL</b>
CLK_VAL	<val> [default value for AUTO is 8, 1 for MANUAL]

Table 12-9. Implementation Parameters

Parameter	Value	Description
LPMTYPE	LPM_DFF	Register category
LPM_HINT	PIPOS	Parallel-in/Parallel-out shift register
	PISO	Parallel-in/Serial-out shift register
	SIPO	Serial-in/Parallel-out shift register
	SISO	Serial-in/Serial-out shift register

Table 12-10. Functional Description<sup>a</sup>

Data	Aclr	Enable	Shiften	Clock	Q <sup>b</sup>	Shiftout <sup>c</sup>
X	0	X	X	X	0	0
X	1	X	X	↓	Q <sub>n</sub>	Q <sub>n</sub> = [WIDTH-1]
X	1	0	0	↑	Q <sub>n</sub>	Q <sub>n</sub> = [WIDTH-1]
X	1	0	1	↑	Q <sub>n</sub> [WIDTH-2:0] && Shiftin	Q <sub>n</sub> = [WIDTH-1]
m	1	1	X	↑	Q <sub>n+1</sub> = m	Q <sub>n+1</sub> = m[WIDTH-1]

a. Aclr is active low, Enable is active high, Shiften is active high, Clock is rising.

b. For the PISO and SISO implementations, Q is an internal register.

c. For the PIPO and SIPO implementations, Shiftout is not present.

# Barrel Shifter

## Features

- Parameterized word length
- Standard or pipelined
- Shift right, left or both
- Wrap around or feed bit
- Fixed or programmable shift.

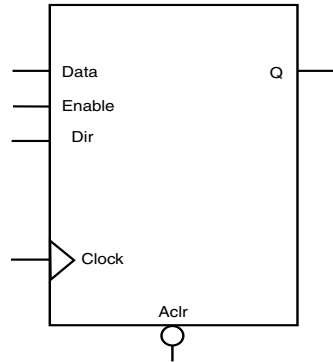

## Family Support

54SX, 54SX-A, eX, 500K, PA

## Description

The Barrel Shifter can be generated for a fixed shift or range of shift, with feedbit shift or rotation in left, right, or both directions. The non-pipelined Barrel Shifter is designed to shift any number of positions at one time. For the pipelined version it takes  $\log_2(\text{MAXSHIFT})$  clock cycles for the shifted data to appear at the output.

The architecture is based on 2 to 1 Multiplexors.

*Table 12-11. Port Description*

Port Name	Size	Type	Req./Opt.	Function
Data	WIDTH	input	Req.	Register load input
Aclr	1	input	Opt.	Asynchronous register reset
Dir	1	input	Opt	For selecting Left or Right shift
RFill	1	input	Opt	For Right Feed Bit
LFill	1	input	Opt	For Left Feed Bit
S0, S1...	Log of Max. Shift	input	Opt	For programmable, depends on Maximum shift
Enable	1	input	Opt.	Synchronous Parallel load enable
Clock	1	input	Req.	Clock
Q	WIDTH	output	Req.	Register output bus

Table 12-12. Parameter Description

Parameter	Value	Function
WIDTH	2-99 (Pipelined) 2-63 (Standard) 2-99 (PA fixed programmable) 2-63 (PA range programmable)	Word length of Data and Q
MAXSHIFT	1-32	Maximum Shift length
CLR_POLARITY	0 1 2	Aclr can be active low, active high or not used
PROG	<b>Fixed</b> or Range	For a Fixed or Programmable shift
FILL	<b>No</b> , Yes	Wrap around or Feed a bit
DIRECTION	<b>Right</b> Left Both	Direction can be Right Left or Both
EN_POLARITY	0 1 2	Enable can be active low, active high
CLK_EDGE	<b>RISE</b> FALL	Clock can be rising or falling

5

Table 12-13. Fan-in Control Parameters

Parameter	Value
CLR_FANIN	AUTO MANUAL
CLR_VAL	<val> [ default value for AUTO is 8, 1 for MANUAL]
EN_FANIN	AUTO MANUAL
EN_VAL	<val> [ default value for AUTO is 6, 1 for MANUAL]
CLK_FANIN	AUTO MANUAL
CLK_VAL	<val> [ default value for AUTO is 8, 1 for MANUAL]
SEL0_FANIN	AUTO MANUAL
SEL0_VAL	<val> [ default value for AUTO is 6, 1 for MANUAL]

Table 12-14. Implementation Parameters

Parameter	Value	Description
LPMTYPE	LPM_DFF	Register category
LPM_HINT	SHIFT, PIPE	Standard or Pipelined

Table 12-15. Functional Description<sup>a</sup> (Standard)

Data	Enable	Clock	Q
M	1	↑	Q <sub>n</sub>
M	0	↑	M <sub>shifted</sub>

a. Assume Aclr is active low, Enable is active high, Clock is rising

Table 12-16. Functional Description<sup>a</sup> (Pipelined)

Data	Aclr	Enable	Clock	Q
X	0	X	X	0's
X	1	0	X	$Q_n = M_{\text{shifted}} - \log_2(\text{MAXSHIFT})$
M	1	1	↑	$Q_{n+1} = M_{\text{shifted}} - \log_2(\text{MAXSHIFT}) + 1$

a. Assume Aclr is active low, Enable is active high, Clock is rising

# Storage Latch

## Features

- Parameterized word length
- Asynchronous clear
- Synchronous latch enable
- Behavioral simulation model in VHDL and Verilog

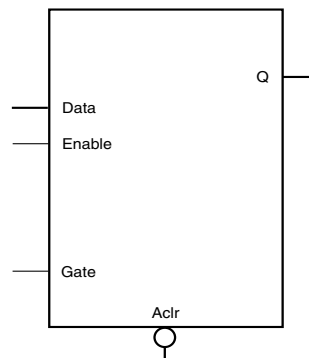

## Family Support

ACT 1, ACT 2/1200XL, ACT 3, 3200DX, 40MX, 42MX 54SX, 54SX-A, eX, 500K, PA, Accelerator

## Description

Latches have a parallel-in/parallel-out architecture (PIPO). The latches are WIDTH bits. The latches are gated on the active high (HIGH) or low (LOW) state of the gate *Gate* (GATE\_POLARITY).

The *Clear* signal (CLR\_POLARITY), when active high or low, provides an asynchronous reset of the latch to “000...0”. You may choose to not implement this function.

The *Enable* signal (EN\_POLARITY), when active high or low, provides a synchronous latch enable operation with respect to the gate *Gate*. You may choose to not implement this function. Latches are then loaded with a new value when both *Enable* and *Gate* are active.

Table 12-17. Port Description

Port Name	Size	Type	Req/Opt	Function
Data	WIDTH	input	Req.	Latch load input
Aclr	1	input	Opt.	Asynchronous latch reset
Enable	1	input	Opt.	Synchronous parallel latch enable
Gate	1	input	Req.	Gate input
Q	WIDTH	output	Req.	Latch output bus

Table 12-18. Parameter Description

Parameter	Family	Value	Function
WIDTH	500K, PA	1-99	Word length of Data and Q
	All other	1-512	
CLR_POLARITY	ALL	0 1 2	AcLr can be active low, active high or not used
EN_POLARITY	ALL	0 1 2	Enable can be active low, active high
GATE_POLARITY	ALL	0 1	Gate can be active low, or active high

Table 12-19. Fan-in Control Parameters

Parameter	Value
CLR_FANIN	<b>AUTO</b> MANUAL
CLR_VAL	<val> [default value for AUTO is 8, 1 for MANUAL]
EN_FANIN	<b>AUTO</b> MANUAL
EN_VAL	<val> [default value for AUTO is 6, 1 for MANUAL]
GATE_FANIN	AUTO <b>MANUAL</b>
GATE_VAL	<val> [default value for AUTO is 8, 1 for MANUAL]

Table 12-20. Implementation Parameters

Parameter	Value	Description
LPMTYPE	LPM_LATCH	Latch category
LPM_HINT	N/A	Not needed



Table 12-21. Functional Description<sup>a</sup>

Data	Aclr	Enable	Gate	Q
X	0	X	X	0's
X	1	X	0	$Q_n$
X	1	0	1	$Q_n$
m	1	1	1	$Q_{n+1} = m$

a. Assume Aclr is active low, Enable is active high, Gate is active high

---

## *Memory Macros for Non-Axcelerator Families*

# Synchronous/Asynchronous Dual Port RAM

## Features

- Parameterized word length and depth
- Dual port synchronous RAM architecture
- Dual port synchronous write, asynchronous read RAM architecture
- 

## Family Support

3200DX, 42MX

## Description

The RAM macros use 3200DX and 42MX, 32x8 or 64x4, dual port RAM cells.

In the synchronous mode, the read and write operations are totally independent and can be performed simultaneously. The operation of the RAM is fully synchronous with respect to the clock signals, *WClock* and *RClock*. Data of value *Data* are written to the *WAddress* of the RAM memory space on the rising (RISE) or falling (FALL) edge of the clock *WClock* (WCLK\_EDGE). Data are read from the RAM memory space at *RAddress* into Q on the rising (RISE) or falling (FALL) edge of the clock signal *RClock* (RCLK\_EDGE).

The behavior of the RAM is unknown if you write and read at the same address and signals *WClock* and *RClock* are not the same. The output Q of the RAM depends on the time relationship between the write and the read clock.

In the asynchronous mode, the operation of the RAM is only synchronous with respect to the clock signal *WClock*. Data of value *Data* are written to the *WAddress* of the RAM memory space on the rising (RISE) or falling (FALL) edge of the clock signal *WClock* (WCLK\_EDGE). Data are read from the RAM memory space at *RAddress* into Q after some delay when *RAddress* has changed.

The behavior of the RAM is unknown if you write and read at the same address. The output Q depends on the time relationship between the write clock and the read address signal.

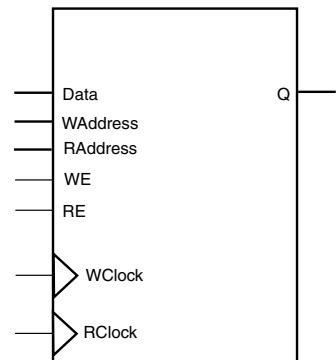

The WIDTH (word length) and DEPTH (number of words) have continuous values but the choice of WIDTH limits the choice of DEPTH and vice versa.

The write enable (*WE*) and read enable (*RE*) signals are active high request signals for writing and reading, respectively; you may choose not to use them.

*Table 13-1. Port Description*

Port Name	Size	Type	Req/Opt	Function
Data	WIDTH	input	Req.	Input Data
WE	1	input	Opt.	Write Enable
RE	1	input	Opt.	Read Enable
WClock	1	input	Req.	Write clock
RClock	1	input	Opt.	Read clock
Q	WIDTH	output	Req.	Output Data

*Table 13-2. Parameter Description*

Parameter	Value	Function
WIDTH	width	Word length of Data and Q
Depth	depth	Number of RAM words
WE_POLARITY	<b>1</b> 2	WE can be active high or not used
RE_POLARITY	<b>1</b> 2	RE can be active high or not used
WCLK_EDGE	<b>RISE</b> FALL	WClock can be rising or falling
RCLK_EDGE	<b>RISE</b> FALL NONE	RClock can be rising, falling or not used

*Table 13-3. Implementation Parameters*

Parameter	Value	Description
LPMTYPE	LPM_RAM_DQ	Generic Dual Port RAM category

Table 13-4. Fan-in Parameters

Parameter	Value	Description
RAMFANIN	AUTO MANUAL	See Fan-in Control section below

Table 13-5. Parameter Rules

Parameter Rules
If RCLK_EDGE is NONE (Asynchronous mode), then RE_POLARITY must be 2 (note used)
The number of RAM blocks used (function of width and depth) must be less than or equal to the number of RAM blocks in one column of the largest device.

## Fan-in Control

One of the key issues when building RAM macros is control of the routing congestion near the RAM cells. The problem becomes more critical when deep RAM macros are built. You need to broadcast signals throughout the height of the chip. The place & route algorithm could have difficulties satisfying all routing constraints. As a result, much slower routing resources could be allocated to satisfy all constraints. To make this problem less likely, a special buffering scheme has been implemented to relieve the congestion near the RAM cells. However, you may choose to control the buffering yourself to improve performances when needed. The RAM macro can be built using either the automatic buffering architecture or the manual buffering architecture.

### Automatic Buffering

In this mode (default), a buffering scheme is automatically built into the RAM macro architecture (see Figure 13-1 on page 134). This mode should always be

considered first. However, if the performance is not met, it may be better to use the manual buffering option .

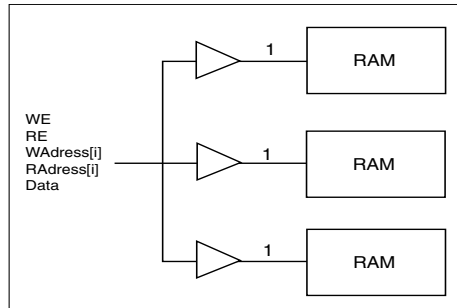

*Figure 13-1. Automatic Buffering for RAM Macros*

### **Manual Buffering**

Figure 13-2 shows how manual buffering is done. A fan-in of one (1) is enforced on all signals fanning out to more than one RAM cell. If these signals were broadcast to all RAM cells, very slow routing resources (long freeways) would be required to route the signals impacting the RAM performance.

Manual buffering should only be used if the expected performance is not realized using the automatic buffering scheme, or if you know ahead of time that you need to use this scheme to meet your timing goals. In this architecture, the idea is not to buffer the signals internally but rather give some kind of access to the RAM macro internal signals. Then, you must buffer the signals outside the macro and either use traditional buffers or duplicate the logic that drives these signals externally. If you choose manual buffering, the *WE*, *RE*, *Waddress(i)*, *RAddress(i)* and *Data[i]* signals become busses external to the macro. For all these signals, the bus width is equal to the number of RAM cells (used to build a given configuration) driven by each signal. Figure 13-2 illustrates the manual buffering architecture for a 96x8 RAM configuration, built of three 32x8 configured RAM cells. In this configuration, the *WE*, *RE*, *WAddress* and *RAddress* signals drive all RAM cells simultaneously. Figure 13-3 shows a 128x8 RAM configuration, built using four 64x4 configured RAM cells. In that

configuration, the 8-bit data bus is split into two completely independent 4-bit data busses.

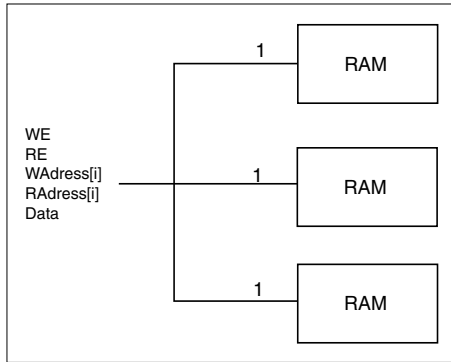

Figure 13-2. Manual Buffering (96x8 RAM Configuration)

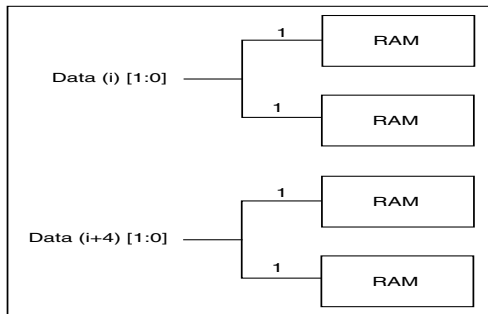

Figure 13-3. Manual Buffering for the Data Bus (128x8 RAM Configuration)

## Timing Waveforms

Table 13-6. Timing Waveform Terminology

Term	Description	Term	Description
$t_{ckhl}$	Clock high/low period	$t_{dsu}$	Data setup time

Table 13-6. Timing Waveform Terminology

Term	Description	Term	Description
$t_{rp}$	Reset pulse width	$t_{rco}$	Data valid after clock high/low
$t_{wesu}$	Write enable setup time	$t_{rao}$	Data valid after read address has changed
$t_{resu}$	Read enable setup time	$t_{co}$	Flip-flop clock to output

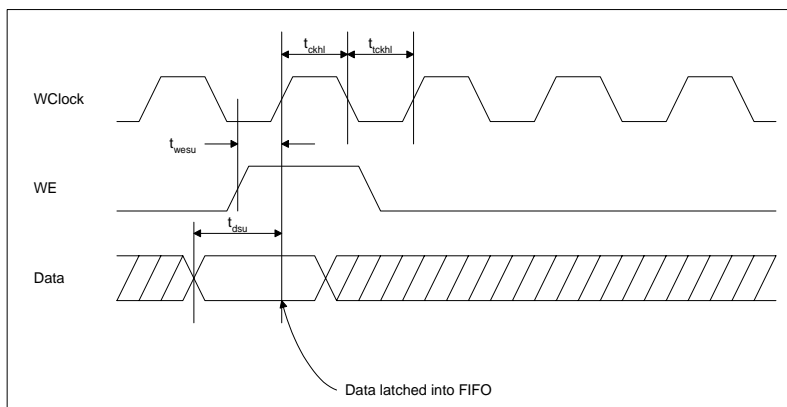

Figure 13-4. RAM Write Cycle



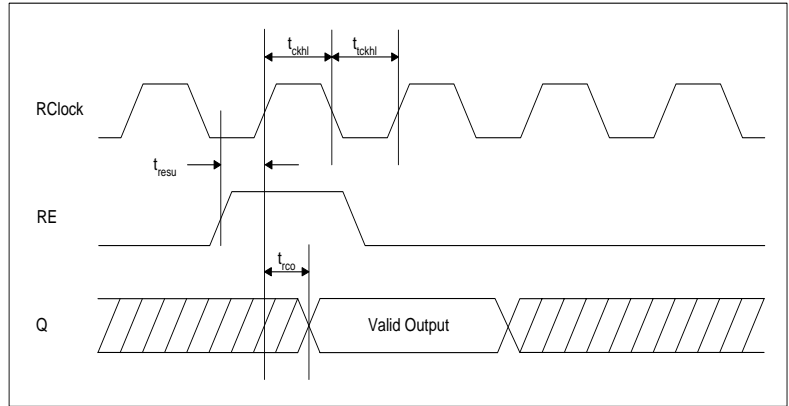

Figure 13-5. RAM Synchronous Read Cycle

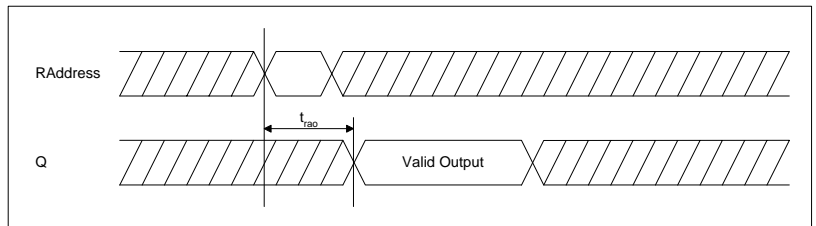

Figure 13-6. RAM Asynchronous Read Cycle

---

# Register File

## Features

- Parameterized word length and depth
- Dual port synchronous RAM architecture
- Dual port synchronous write, asynchronous read RAM architecture
- Write and Read enable
- Behavioral simulation model in VHDL and Verilog

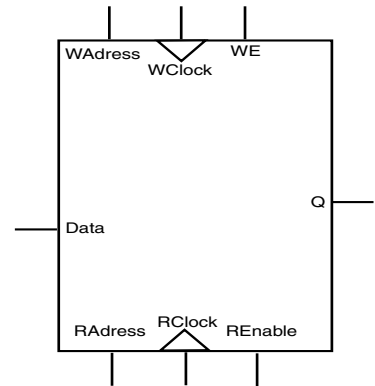

## Family Support

54SX, 54SX-A, eX

## Description

The register file is a macro unique to the 54SX, 54SX-A and eX families. This macro synthesizes the equivalent of small RAM blocks using ordinary logic, thereby making memory cells available to you even though the silicon does not explicitly have hardware support for RAM.

In synchronous mode, the read and write operations are totally independent and can be performed simultaneously. The operation of the register is fully synchronous with respect to the clock signals WClock and RClock. Data of value Data are written to the WAddress of the register memory space on the rising (RISE) or falling (FALL) edge of the clock WClock (WCLK\_EDGE). Data are read from the register memory space at RAddress into Q on the rising (RISE) or falling (FALL) edge of the clock RClock (RCLK\_EDGE).

The behavior of the Register is unknown, if designers write and read at the same address and WClock and RClock are not the same. The output Q of the register depends on the time relationship between the write and the read clock.

In asynchronous mode, the operation of the register is only synchronous with respect to the clock signal WClock. Data of value Data are written to the WAddress of the register memory space on the rising (RISE) or falling (FALL) edge of the clock WClock

(WCLK\_EDGE). Data are read from the register memory space at RAddress into Q after some delay when RAddress has changed.

The WIDTH (word length) and DEPTH (number of words) have continuous values but the choice of WIDTH limits the choice of DEPTH and vice versa.

The write enable (WE) and read enable (RE) signals are active high request signals for writing and reading, respectively. The user may not utilize them.

*Table 13-7. Port Description*

<b>Port Name</b>	<b>Size</b>	<b>Type</b>
Data	WIDTH	input
WE	1	input
RE	1	input
WClock	1	input
RClock	1	input
Q	WIDTH	output

*Table 13-8. Parameter Description*

<b>Parameter</b>	<b>Value</b>	<b>Function</b>
WIDTH	width	Word length of Data and Q
DEPTH	depth	Number of RAM words
WE_POLARITY	<b>1 2</b>	<i>WE</i> can be active high or not used
RE_POLARITY	<b>1 2</b>	<i>RE</i> can be active high or not used
WCLK_EDGE	<b>RISE FALL</b>	<i>WClock</i> can be rising or falling
RCLK_EDGE	<b>RISE FALL NONE</b>	<i>RClock</i> can be rising, falling or not used

Timing Waveforms

Table 13-9. Timing Waveform Terminology

Term	Description	Term	Description
$t_{ckhl}$	Clock high/low period	$t_{dsu}$	Data setup time
$t_{rp}$	Reset pulse width	$t_{rco}$	Data valid after clock high/low
$t_{wesu}$	Write enable setup time	$t_{rao}$	Data valid after read address has changed
$t_{resu}$	Read enable setup time	$t_{co}$	Flip-flop clock to output

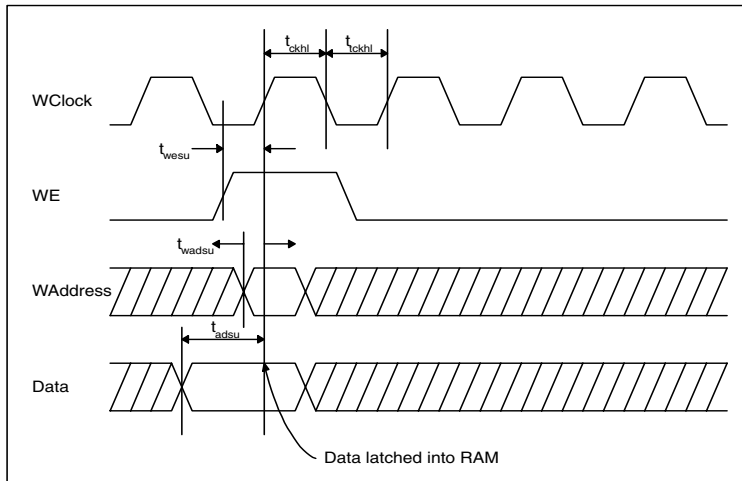

Figure 13-7. Ram Write Cycle

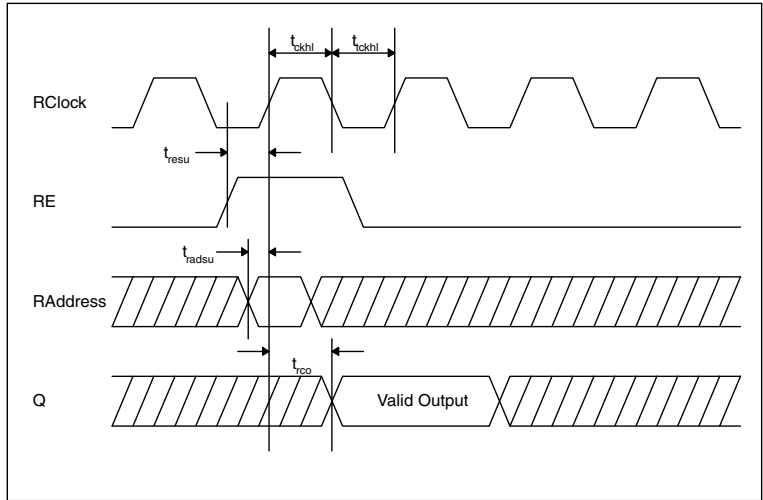

Figure 13-8. RAM Synchronous Read Cycle

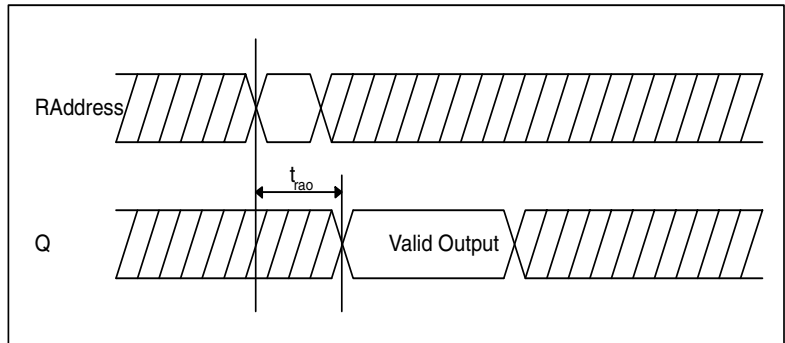

Figure 13-9. RAM Asynchronous Read Cycle

---

# Synchronous Dual Port FIFO without Flags

## Features

- On-chip RAM
- Parameterized word length and depth
- Dual port synchronous FIFO (write and read clocks are separated) with no static flag logic
- Global reset of FIFO address pointers

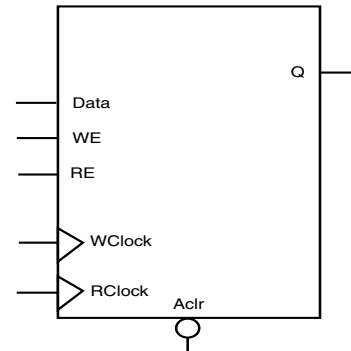

## Family Support

3200DX, 42MX, 54SX, 54SX-A, eX

## Description

The ACTgen FIFO macros use the 3200DX and 42MX 32x8 or 64x4 on-chip RAM cells. ACTgen generates addresses internally using counters and token chains to address the RAM blocks (transparent to the user). Dedicated read and write address data paths are used in the FIFO architecture. The read and write operations are independent and can be performed simultaneously.

The WIDTH (word length) and DEPTH (number of words) have continuous values but the choice of WIDTH limits the choice of DEPTH and vice versa.

The asynchronous clear signal, *Aclr*, can be active low or active high (low is the default option and is the preferred use for all synchronous elements in the two supported families). When the asynchronous clear is active, all internal registers used to determine the current FIFO read and write addresses (counters and token chains) are reset to “0.” The FIFO is now in an empty state; the RAM content is not affected. When power is first applied to the FIFO, the FIFO must be initialized with an asynchronous clear cycle to reset the internal address pointers.

The write enable *WE* and read enable *RE* signals are active high request signals for writing into and reading out of the FIFO respectively. The *WE* and *RE* signals only control the logic associated with the FIFO write and read address pointers.

When *WE* is asserted high, the write cycle is initiated, and Data are written into the FIFO. The design using the FIFO is responsible for handling the full and empty states of the FIFO macro.

When *RE* is asserted high, the read cycle is initiated, and Q is read from the FIFO. The design using the FIFO is responsible for handling the full and empty states of the FIFO macro.

Table 13-10. Port Description

Port Name	Size	Type	Req/Opt	Function
Data	WIDTH	input	Req.	Input Data
WE	1	input	Req.	Write Enable
RE	1	input	Req.	Read Enable
WClock	1	input	Req.	Write clock
RClock	1	input	Req.	Read clock
Q	WIDTH	output	Req.	Output Data

Table 13-11. Parameter Description

Parameter	Value	Function
WIDTH	width	Word length of Data and Q
DEPTH	depth	Number of FIFO words
WCLK_EDGE	<b>RISE</b> FALL	WClock can be rising or falling
RCLK_EDGE	<b>RISE</b> FALL	RClock can be rising falling

Table 13-12. Implementation Parameters - MX/DX

Parameter	Value	Description
LPMTYPE	LPM_FIFO_DQ	Generic FIFO category
LPM_HINT	SFIFO	Synchronous FIFO with no flags

Table 13-13. Implementation Parameters - 54SX/SX-A

Parameter	Value	Description
LPM_HINT	SFIFOSX	Synchronous FIFO with no flags

Table 13-14. Fan-in Parameters

Parameter	Value	Description
RAMFANIN	<b>AUTO</b> MANUAL	See “Fan-in Control” on page 133

## Timing Waveforms

Table 13-15. Timing Waveform Terminology

Term	Description	Term	Description
$t_{ckhl}$	Clock high/low period	$t_{dsu}$	Data setup time
$t_{rp}$	Reset pulse width	$t_{rco}$	Data valid after clock high/low
$t_{wesu}$	Write enable setup time	$t_{co}$	Flip-flop clock to output
$t_{resu}$	Read enable setup time		



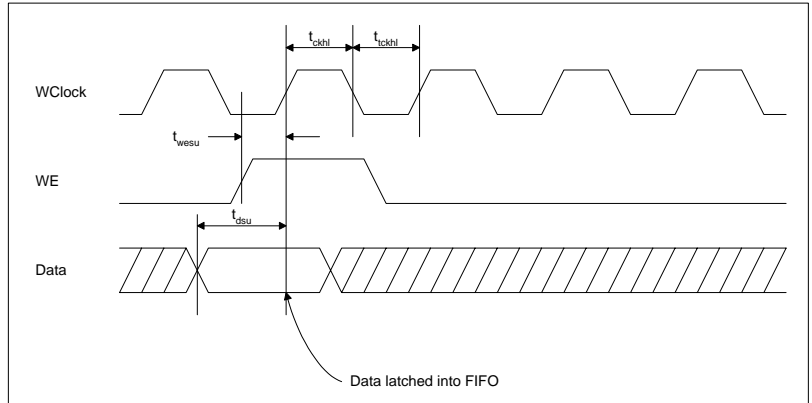

Figure 13-10. FIFO Write Cycle

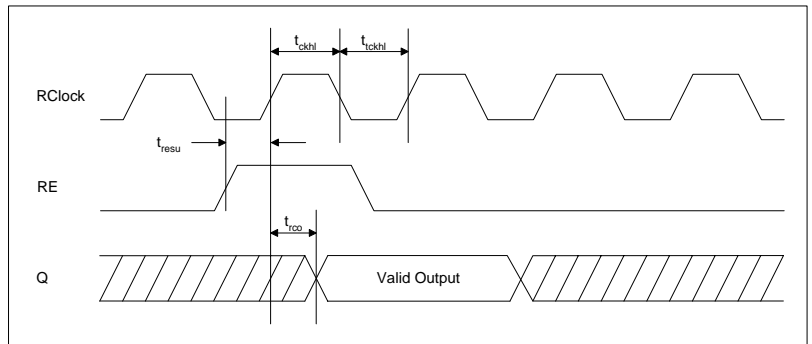

Figure 13-11. FIFO Read Cycle

---

# Synchronous Dual Port FIFO with Flags

## Features

- On-chip RAM
- Parameterized word length and depth
- FIFO full and empty flags
- Statically programmable almost-full flag to indicate when the FIFO macro reaches a specific level, usually when writing into the FIFO
- Statically programmable almost-empty flag to indicate when the FIFO macro reaches a specific level, usually when reading from the FIFO
- Global reset of the FIFO address pointers and flag logic
- Dual port synchronous FIFO

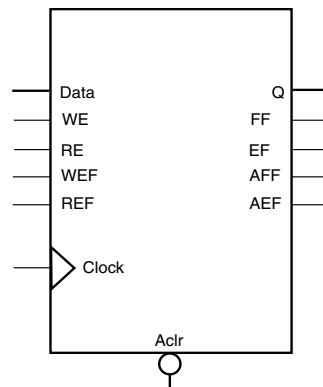

## Family Support

3200DX, 42MX, 54SX, 54SX-A, eX

## Description

The ACTgen FIFO macros use the 3200DX and 42MX 32x8 or 64x4 dual-port RAM cells. Addresses are generated internally using counters and token chains to address the RAM (this is transparent to the user). Dedicated read and write address data paths are used in the FIFO architecture. The read and write operations are totally independent and can be performed simultaneously.

The WIDTH (word length) and DEPTH (number of words) have continuous values but the choice of WIDTH limits the choice of DEPTH and vice versa.

The asynchronous clear signal, *Aclr*, can be active low or active high (low is the default option and should be used for all synchronous elements in the two supported families). When the asynchronous clear is active, all internal registers used to determine the current FIFO read and write addresses (counters and token chains) are reset to “0.”

The FIFO is now in an empty state; the RAM content is not affected. When power is first applied to the FIFO, the FIFO must be initialized with an asynchronous clear cycle to reset the internal address pointers.

The full flag signal, *FF*, is optional and is available only for the High Speed Flag (FFIFO) and the Medium Speed Flag (MFFIFO) variations. The *FF* signal is active high only (if selected) and indicates when the FIFO is full. The signal is asserted high on the rising (RISE) or falling (FALL) edge of the clock signal *Clock* with no delay.

The empty flag signal, *EF*, is optional and is available only for the High Speed Flag (FFIFO) and the Medium Speed Flag (MFFIFO) variations. The *EF* signal is active low only (if selected) and indicates when the FIFO is empty. The signal is asserted low on the rising (RISE) or falling (FALL) edge of the clock signal *Clock* with no delay.

The write enable signals, *WE* and *WEF*, and read enable signals, *RE* and *REF*, are active high requests for writing into and reading out of the FIFO respectively. The *WE* and *RE* signals only control the logic associated with the FIFO write and read address pointers. The *WEF* and *REF* signals control the logic implementing the different flags. The *WE* and *WEF* signals should be logically driven by the same logic outside the FIFO macro. The same behavior applies to the *RE* and *REF* signals as well. For SX and SX-A there are only the RE and WE ports.

When *WE* is asserted high and *FF* is asserted low (not full), the write cycle is initiated and Data are written into the FIFO. When *WE* is asserted high and *FF* is asserted high (full), the FIFO behavior is undefined. When *RE* is asserted high and *EF* is asserted high (empty), the read cycle is initiated and Q is read from the FIFO. When *RE* is asserted high and *EF* is asserted low (empty), the FIFO behavior is undefined. When *RE* and *WE* are asserted high at the same time, Data are written into the FIFO and Q is read from the FIFO simultaneously. The read and write operations are fully synchronous with respect to the clock signal *Clock*.

The FIFO function offers a parameterizable almost-full flag, *AFF*. The *AFF* flag is asserted high when the FIFO contains *aff\_val* words or more as defined by the parameter *AFF\_VAL*. Otherwise, *AFF* is asserted low. The *aff\_val* value is a parameter to the macro, and thus logic is built at generation time to realize the almost-full flag function.

The FIFO function offers a parameterizable almost-empty flag, *AEF*. The *AEF* flag is asserted low when the FIFO contains *aef\_val* words or less as defined by the parameter *AEF\_VAL*. Otherwise, *AEF* is asserted low. The *aef\_val* value is a parameter to the macro, and thus logic is built at generation time to realize the almost-empty flag function.

Table 13-16. Port Description

Port Name	Size	Type	Req./Opt.	Function
Data	WIDTH	input	Req.	Input Data
WE	1	input	Req.	Write Enable with the FIFO only (no flag)
RE	1	input	Req.	Read Enable with the FIFO only (no flag)
WEF	1	input	Req.	Write enable associated with the flag logic only (for DX/MX)
REF	1	input	Req.	Read enable associated with the flag logic only (for DX/MX)
Clock	1	input	Req.	Write and read clock
Q	WIDTH	output	Req.	Output Data
FF	1	output	Req.	Full Flag
EF	1	output	Req.	Empty Flag
AFF	1	output	Optional	Almost Full Flag
AEF	1	output	Optional	Almost Empty Flag

Table 13-17. Parameter Description

Parameter	Value	Function
WIDTH	width	Word length of Data and Q
DEPTH	depth	Number of FIFO words
FF_POLOARITY	1 2	FF can be active high or not

Table 13-17. Parameter Description (Continued)

Parameter	Value	Function
EF_POLARITY	<b>0</b> 2	EF can be active low or not used
AFF_VAL	aff_val (see parameter rules)	AFF value (not used if aff_val is 0)
AEF_VAL	aef_val (see parameter rules)	AEF value (not used if aef_val is 0)
CLK_EDGE	<b>RISE</b> FALL	Clock can be rising or falling

Table 13-18. Implementation Parameters - MX/DX

Parameter	Value	Description
LPMTYPE	LPM_FIFO_DQ	Generic FIFO category
LPM_HINT	FFIFO	High speed FIFO with flags
	MFFIFO	Medium speed FIFO with flags

Table 13-19. Implementation Parameters - 54SX/SX-A

Parameter	Value	Description
LPM_HINT	FFIFOSX	Synchronous FIFO with no flags

Table 13-20. Fan-in Parameters

Parameter	Value	Description
RAMFANIN	<b>AUTO</b> MANUAL	See Fan-in Control section below

Table 13-21. Parameter Rules

Parameter Rules
If RCLK_EDGE is NONE (Asynchronous mode), then RE_POLARITY must be 2 (not used)

## Timing Waveforms

Table 13-22. Timing Waveform Terminology

Term	Description
$t_{ckhl}$	Clock high/low period
$t_{rp}$	Reset pulse width
$t_{wesu}$	Write enable setup time
$t_{resu}$	Read enable setup time
$t_{adsu}$	Data setup time
$t_{tco}$	Data valid after lock high/low
$t_{rao}$	Data valid after read address has changed
$t_{co}$	Flip-flop clock to output

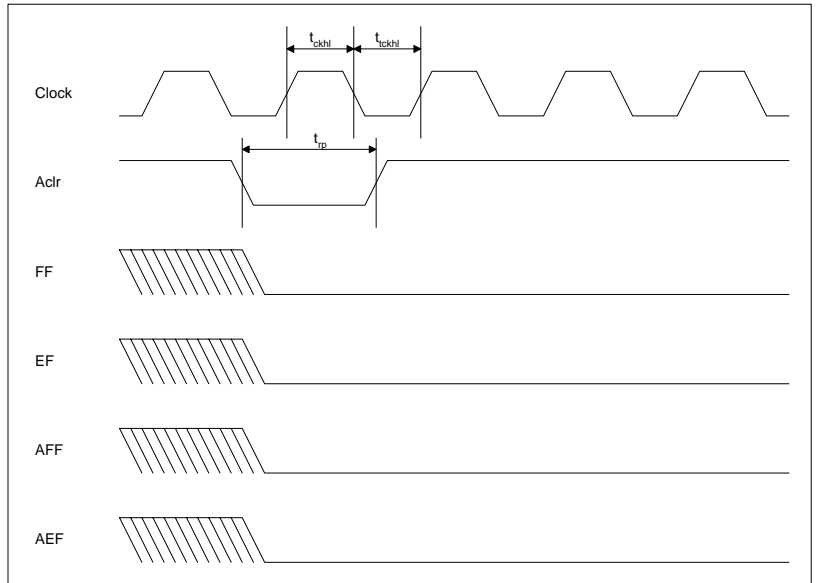

Figure 13-12. Reset Cycle

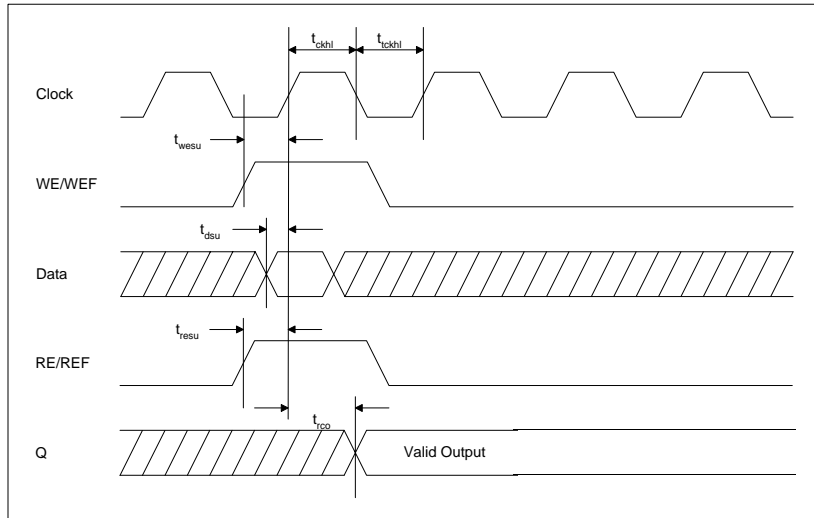

Figure 13-13. Write and Read Cycle

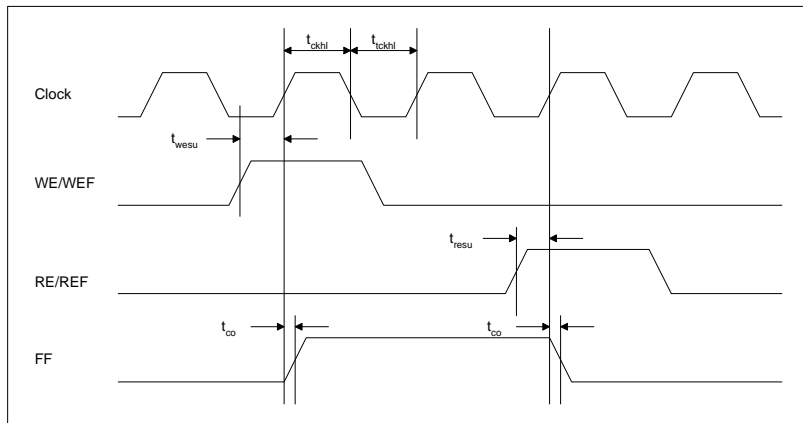

Figure 13-14. Full FIFO Timing Diagram



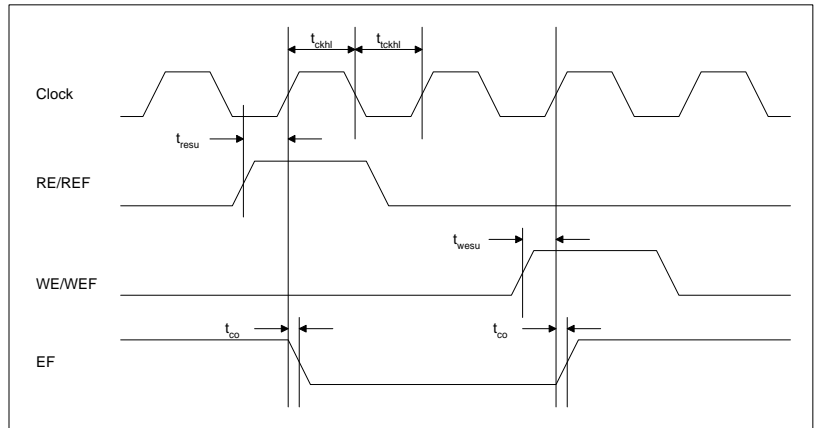

Figure 13-15. Empty FIFO Timing Diagram

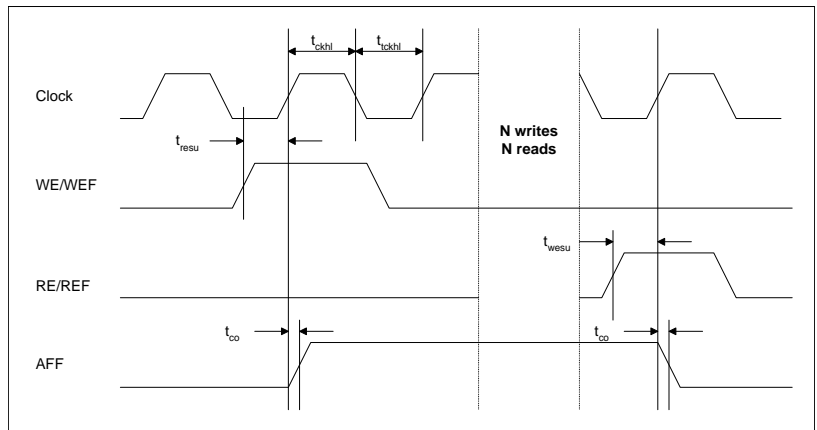

Figure 13-16. Almost Full FIFO Timing Diagram

---

# FIFO Flag Controller (No RAM)

## Features

- Off-chip RAM
- Parameterized word length and depth
- FIFO full and empty flags
- Statically programmable almost-full flag to indicate when the FIFO macro reaches a specific level, usually when writing into the FIFO
- Statically programmable almost-empty flag to indicate when the FIFO macro reaches a specific level, usually when reading from the FIFO
- Global reset of the FIFO address pointers and flag logic

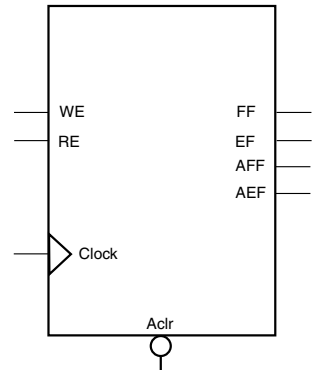

## Family Support

3200DX, 42MX, 54SX, 54SX-A, eX

## Description

The ACTgen FIFO Flag Controller is designed for off-chip RAM. It is a state machine generating the Flags typically used by a FIFO.

The asynchronous clear (*Aclr*) can be active low or active high (low is the default option and should be preferably used as for all synchronous elements in the two supported families). We will further use the word active to specify the state of a given signal. When the asynchronous clear is active, all internal registers are reset to '0'. The FIFO Controller is now in an empty state. At power up time, the FIFO must be initialized with a asynchronous clear cycle.

The full flag signal *FF* is optional. The *FF* signal is active high only (if selected) and indicates when the FIFO is full. The signal is asserted high on the rising (RISE) or falling (FALL) edge of the clock signal *Clock* with no delay.

The empty flag signal *EF* is optional. The *EF* signal is active low only (if selected) and indicates when the FIFO is empty. The signal is

asserted low on the rising (RISE) or falling (FALL) edge of the clock signal *Clock* with no delay.

The write enable (*WE*) and read enable (*RE*) signals are active high requests signals for for controlling the FIFO flags. They should be logically equivalent to the write and read enable controlling the off-chip RAM.

The FIFO Controller offers a parameterizable almost-full flag (*AFF*). The *AFF* flag is asserted high when the FIFO contains *aff\_val* words or more as defined by the parameter *AFF\_VAL*. Otherwise, *AFF* is asserted low. The value *aff\_val* value is a parameter to the macro, and thus logic is built at generation time to realize the almost-full flag function.

The FIFO Controller offers a parameterizable almost-empty flag (*AEF*). The *AEF* flag is asserted low when the FIFO contains *aef\_val* words or less as defined by the parameter *AEF\_VAL*. Otherwise, *AEF* is asserted low. The value *aef\_val* value is a parameter to the macro, and thus logic is built at generation time to realize the almost-empty flag function.

*Table 13-23. Port Description*

<b>Port Name</b>	<b>Size</b>	<b>Type</b>	<b>Req/Opt?</b>	<b>Function</b>
Clock	1	input	Req.	Write and read clock
WE	1	input	Req.	Write enable associated to the flag logic only
RE	1	input	Req.	Read enable associated to the flag logic only
Aclr	1	input	Req.	Asynchronous Clear
EF	1	output	Opt.	Empty Flag
FF	1	output	Opt.	Full Flag
AEF	1	output	Opt.	Almost Empty Flag
AFF	1	output	Opt.	Almost Full Flag

Table 13-24. Parameter Description

Parameter	Value	Function
WIDTH	width	Word length of Data and Q
DEPTH	depth	Number of FIFO words
FF_POLARITY	<b>1</b> 2	FF can be active high or not used
EF_POLARITY	<b>0</b> 2	EF can be active low or not used
AFE_VAL	aff_val (see parameter rules)	AFE value (not used if aff_val is 0)
AEE_VAL	aef_val (see parameter rules)	AEE value (not used if aef_val is 0)
CLK_EDGE	<b>RISE</b> FALL	Clock can be rising or falling

Table 13-25. Implementation Parameters - MX/DX

Parameter	Value	Description
LPM_TYPE	LPM_FIFO_DQ	Generic FIFO category
LPM_HINT	FFIFOCTRL	High speed FIFO Controller
	MFFIFOCTRL	Medium speed FIFO Controller

Table 13-26. Implementation Parameters - 54SX/SX-A/eX

Parameter	Value	Description
LPM_HINT	FCR	FIFO Controller

*Table 13-27. Fan-In Parameters*

<b>Parameter</b>	<b>Value</b>	<b>Description</b>
CLR_FANIN	<b>AUTO</b> MANUAL	See Fan-in Control section
CLK_FANIN	AUTO <b>MANUAL</b>	See Fan-in Control section
WE_FANIN	<b>AUTO</b> MANUAL	See Fan-in Control section
RE_FANIN	<b>AUTO</b> MANUAL	See Fan-in Control section

---

## *Memory Macros for Axcelerator*

---

# Axcelerator RAM

## Features

- Parameterized word length and depth
- Dual port synchronous RAM architecture
- Independent Read/Write Sizes
- Active High/Low enable
- Non-pipelined (synchronous - one clock edge)/  
Pipelined (synchronous - two clock edges) Read
- Port mapping

## Family support

Axcelerator

## Description

Axcelerator provides dedicated blocks of RAM. Each block has a read port and a write port. Both ports are configurable to any size from 4Kx1 to 128x36; thereby, allowing built-in bus width conversion (see SRAM Port Aspect Ratio table below). Each port is completely independent and fully synchronous.

*Table 14-1. SRAM Port Aspect Ratio*

Width	Depth	ADDR Bus	Data Bus
1	4096	ADDR[11:0]	DATA[0]
2	2048	ADDR[10:0]	DATA[1:0]
4	1024	ADDR[9:0]	DATA[3:0]
9	512	ADDR[8:0]	DATA[8:0]
18	256	ADDR[7:0]	DATA[17:0]
36	128	ADDR[6:0]	DATA[35:0]

## Modes

The three major modes available for read and write operations are:

1. Read Non-pipelined (synchronous - one clock edge)  
The read address is registered on the read port clock edge and data appears at read-data after the RAM access time (when all RENs are high, approximately 4.5ns). The setup time of the read address and read enable are minimal with respect to the read clock. Setting the Pipeline to OFF enables this mode.
2. Read Pipelined (synchronous - two clock edges)  
The read-address is registered on the read port clock edge and the data is registered and appears at read-data after the second read clock edge. Setting the Pipeline to ON enables this mode.
3. Write (synchronous - one clock edge)  
On the write clock edge, the write data are written into the USRAM at the write address (when all WENs are high). The setup time of the write address, write enables and write data are minimal with respect to the read clock.

## Cascading Blocks

Blocks can be cascaded to create larger sizes, up to the capacity of one whole column of RAM blocks. ACTgen performs all the necessary cascading for achieving the desired configuration.

The WIDTH (word length) and DEPTH (number of words) have continuous values but the choice of WIDTH limits the choice of DEPTH and vice versa.

The Read/Write Width/Depth can be different but the Aspect ratio should be same for both. For example:

$$\text{Read Width} * \text{Read Depth} == \text{Write Width} * \text{Write Depth}$$

The write enable (WE) and read enable (RE) signals are active high or low request signals for writing and reading, respectively; you may choose not to use them.

The RCLK and WCLK pins have independent polarity selection.

## Conflict Resolution

There is no special hardware for handling read and write operations at the same addresses.



Table 14-2. Port Description

Name	Size	Type	Req/Opt	Function
Data	Write Width	Input	Req	Write Data Port
WAddress	$\log_2(\text{Write Depth})$	Input	Req	Write Address Bus
WE	1	Input	Opt	Write Enable
WClock	1	Input	Req	Write Clock
Q	Read Width	Output	Req	Read Data Port
RAddress	$\log_2(\text{Read Depth})$	Input	Req	Read Address Bus
RE	1	Input	Opt	Read Enable
RClock	1	Input	Req	Read Clock

Table 14-3. Parameter Description

Parameter	Value	Function
WWIDTH	Write Width	Word length of Data
WDEPTH	Write Depth	Number of Write Words
RWIDTH	Read Width	Word length of Q
RDEPTH	Read Depth	Number of Read Words
WE_POLARITY	1 0 2	Write Enable Polarity
RE_POLARITY	1 0 2	Read Enable Polarity
WCLK_EDGE	RISE FALL	Write Clock Edge
RCLK_EDGE	RISE FALL	Read Clock Edge
PIPE	NO YES	Read Pipeline
DEVICE	75 150 300 600 1000 (May change)	Target Device, to determine blocks available for cascading

*Table 14-4. Implementation Parameters*

<b>Parameter</b>	<b>Value</b>	<b>Description</b>
LPMTYPE	LPM_RAM	Generic Dual Port RAM Category

*Table 14-5. Parameter Rules*

<b>Device</b>	<b>Parameter rules</b>
Axcelerator	$RWIDTH * RDEPTH == WWIDTH * WDEPTH$

---

# Axcelerator FIFO

## Features

- Parameterized word length and FIFO depth
- Dual port synchronous FIFO
- Active High/Low enable
- Static/ Programmable/No Almost empty/full flags
- Full and Empty flags

## Family support

Axcelerator

## Description

Axcelerator provides dedicated blocks of FIFO. They are actually hardwired using the RAM blocks plus some control logic. Each FIFO block has a read port and a write port. Both ports are configurable (to the same size) to any size from 4Kx1 to 128x36; thereby, allowing built-in bus width conversion (see SRAM Port Aspect Ratio table below). Each port is fully synchronous. The FIFO block offers programmable Almost Empty and Almost Full flags as well as Empty and Full flags. The FIFO block may be reset to the empty state.

*Table 14-6. SRAM Port Aspect Ratio*

Width	Depth	ADDR Bus	Data Bus
1	4096	ADDR[11:0]	DATA[0]
2	2048	ADDR[10:0]	DATA[1:0]
4	1024	ADDR[9:0]	DATA[3:0]
9	512	ADDR[8:0]	DATA[8:0]
18	256	ADDR[7:0]	DATA[17:0]
36	128	ADDR[6:0]	DATA[35:0]

## Cascading Blocks

Blocks can be cascaded to create larger sizes, up to the capacity of one whole column of RAM blocks. ACTgen performs all the necessary cascading for achieving the desired configuration.

The WIDTH (word length) and DEPTH (number of words) have continuous values but the choice of WIDTH limits the choice of DEPTH and vice versa. The write enable (WE) and read enable (RE) signals are active high or low request signals for writing and reading, respectively; you may choose not to use them.

The RCLK and WCLK pins have independent polarity selection.

*Table 14-7. Port Description*

<b>Name</b>	<b>Size</b>	<b>Type</b>	<b>Req/Opt</b>	<b>Function</b>
Data	Width	Input	Req	Data Port
WE	1	Input	Opt	Write Enable
WClock	1	Input	Req	Write Clock
Q	Width	Output	Req	Q Port
RE	1	Input	Opt	Read Enable
RClock	1	Input	Req	Read Clock
Full	1	Output	Req	Full Flag
Empty	1	Output	Req	Empty Flag
Afval	1-8	Input	Opt	Almost Full, Dynamically programmable
Aeval	1-8	Input	Opt	Almost Empty, Dynamically programmable
AFull	1-8	Output	Opt	Almost Full Flag
AEmpty	1-8	Output	Opt	Almost Empty Flag

Table 14-8. Parameter Description

Parameter	Value	Function
WIDTH	Width	Word length of Data, Q
DEPTH	Depth	FIFO Depth
WE_POLARITY	1 0 2	Write Enable Polarity
RE_POLARITY	1 0 2	Read Enable Polarity
WCLK_EDGE	<b>RISE</b> FALL	Write Clock Edge
RCLK_EDGE	<b>RISE</b> FALL	Read Clock Edge
AEVAL	Almost Empty Value	Almost Empty Flag
AFVAL	Almost Full Value	Almost Full Flag
DEVICE	75 150 300 600 1000 (May change)	Target Device, to determine blocks available for cascading

Table 14-9. Implementation Parameters

Parameter	Value	Description
LPM_TYPE	LPM_FIFO	Generic Dual Port FIFO Category
LPM_HINT	STATIC	Static AF/AE Flags
	DYNAMIC	Dynamic AF/AE Flags
	NOFLAGS	No AF/AE Flags

Table 14-10. Parameter Rules

Device	Parameter rules	
Axcelerator	WIDTH	AEVAL/AFVAL UNITS
	000	$2^{8-W}$
	001	
	010	
	011	
	100	
	101	
	11x	

---

## *PerPin FIFO*

The PerPin FIFO macro is included in the IOs section of the manual on page 89.

---

## *Memory Macros for ProASIC*



# Synchronous/Asynchronous Dual Port RAM for ProASIC

## Features

- Parameterized word length and depth
- Dual port RAM architecture
- Asynchronous, synchronous-transparent or synchronous-pipelined read
- Asynchronous, or synchronous write
- Parity check or generate, both even and odd
- Supported netlist formats: EDIF, VHDL and Verilog

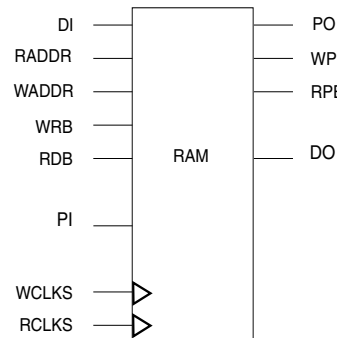

## Family support

500K, PA

## Description

There is no limitation for depth and width. However, it is your responsibility to insure that the RAM's used in a design can physically fit on the device chosen for the design.

Table 15-1. Port Description

Port Name	Size	Type	Req/Opt?	Function
DI	WIDTH	input	Req.	Input Data
RADDR	log2 (DEPTH)	input	Req.	Read Address
WADDR	log2 (DEPTH)	input	Req.	Write Address
WRB	1	input	Req.	Write pulse (low active)
RDB	1	input	Req.	Read pulse (low active)
WCLK	1	input	Req.	Write Clock
RCLK	1	input	Req.	Read Clock
DO	WIDTH	output	Req.	Output data

*Table 15-1. Port Description (Continued)*

PI	WIDTH	input	Opt.	Input parity bits
PO	log2(WIDTH)	output	Opt.	Parity bits
WPE	1	output	Opt.	Write parity error flag
RPE	1	output	Opt.	Read parity error flag

*Table 15-2. Parameter Description*

Parameter	Value	Function
WIDTH	width	Word length of DI and DO
DEPTH	depth	Number of RAM words
RDA	async transparent pipelined	Read Data Access
WRA	async sync	Write Data Access
OPT	speed area	Optimization
PARITY	checkeven check-odd geneven genodd none	Parity check or parity generation

*Table 15-3. Implementation Parameters*

Parameter	Value	Description
LPMTYPE	LPM_RAM_DQ	Generic Dual Port RAM category

**Timing Waveforms**

Please refer to the timing waveforms presented in:

- *ProASIC A500K Family Datasheet*

# Register File for ProASIC

## Features

- Parameterized word length and depth
- Two port asynchronous register file
- Rising edge triggered or level-sensitive
- Supported netlist formats:  
VHDL and Verilog

## Family support

500K, PA



## Description

Distributed memory can be generated as a two port asynchronous register file or as an asynchronous FIFO. Distributed memories are made up of the logic tiles of the device. These memory files are netlists consisting of logic tiles and do not use embedded memory cells.

When generating Register File macros for ProASIC, you interact with the ACTgen user interface instead of the command line based Distributed MEMORYmaster.

Please refer to “Memory in ProASIC” on page 180 for more detailed descriptions of ProASIC's Distributed Memories.

*Table 15-4. Port Description*

Port Name	Size	Type	Req/Opt?	Function
wData<i>	1	Input	Req.	Input (Write) Data (i = 0 .. WIDTH-1)
wAddr<i>	1	Input	Req.	Write Address (i = 0 .. log2(WIDTH)-1)
rAddr<i>	1	Input	Req.	Read Address (i = 0 .. log2(WIDTH)-1)
WR	1	Input	Req.	Write Clock/Pulse (rising edge triggered or level sensitive)
rData<i>	1	Output	Req.	Output (Read) Data (i = 0 .. WIDTH-1)

*Table 15-5. Parameter Description*

Parameter	Value	Function
WIDTH	See "Parameter Rules"	Word length input/output data
DEPTH	2..48	Number of words for APA150
	2..64	Number of words for all other devices
TRIGGER	<b>edge</b> , level	Select between rising edge triggered and level sensitive write clock

*Table 15-6. Implementation Parameters*

Parameter	Value	Description
LPMTYPE	LPM_DIST_RAM	Generic Register File category
LPM_HINT	RAM_DISTH<#>	Horizontal Orientation; # represents the part number, and can be 050, 130, 180, 270 for 500K 150, 300, 450, 600, 750, 1000 for PA
	RAM_DISTV<#>	Vertical Orientation

*Table 15-7. Parameter Rules*

Device	Orientation	Parameter rules
A500K050	Horizontal	WIDTH = 2..30
	Vertical	WIDTH = 2..46
A500K130	Horizontal	WIDTH = 2..38
	Vertical	WIDTH = 2..78
A500K180	Horizontal	WIDTH = 2..46
	Vertical	WIDTH = 2..94
A500K270	Horizontal	WIDTH = 2..58
	Vertical	WIDTH = 2..110
APA150	Horizontal	WIDTH = 2..22
	Vertical	WIDTH = 2..62
APA300	Horizontal	WIDTH = 2..30
	Vertical	WIDTH = 2..62

Table 15-7. Parameter Rules (Continued)

Device	Orientation	Parameter rules
APA450	Horizontal	WIDTH = 2..30
	Vertical	WIDTH = 2..94
APA600	Horizontal	WIDTH = 2..46
	Vertical	WIDTH = 2..110
APA750	Horizontal	WIDTH = 2..62
	Vertical	WIDTH = 2..126
APA1000	Horizontal	WIDTH = 2..78
	Vertical	WIDTH = 2..174

## Timing Waveforms

Please refer to the timing waveforms presented in “Memory in ProASIC” on page 180 for more information.

# Synchronous/Asynchronous Dual Port FIFO for ProASIC

## Features

- Parameterized word length and depth
- Dual port RAM architecture
- Asynchronous, synchronous transparent or synchronous pipelined read
- Asynchronous, or synchronous write
- Parity check or generate, both even and odd
- Supported netlist formats: EDIF, VHDL and Verilog

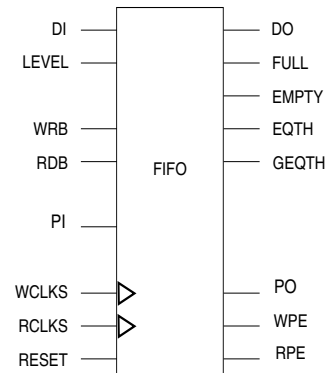

## Family support

500K, PA

## Description

There is no limitation for depth and width. However, it is your responsibility to insure that the FIFOs used in a design can physically fit on the device chosen for the design.

Table 15-8. Port Description

Port Name	Size	Type	Req/Opt?	Function
DI	WIDTH	input	Req.	Input Data
LEVEL	8 <sup>a</sup>	input	Opt.	Defines level when EQTH and GEQTH should react (hardcoded for static trigger Level)
WRB	1	input	Req.	Write pulse (low active)
RDB	1	input	Req.	Read pulse (low active)
WCLK	1	input	Req.	Write Clock
RCLK	1	input	Req.	Read Clock
RESET	1	input	Req.	Reset for FIFO pointers
DO	WIDTH	output	Req.	Output data

Table 15-8. Port Description (Continued)

EMPTY	1	output	Req.	Empty flag
FULL	1	output	Req.	Full flag
EQTH	1	output	Req.	Flag is true when FIFO hold (LEVEL) words
GEQTH	1	output	Req.	Flag is true when FIFO hold (LEVEL) words or more
PI	WIDTH	input	Opt.	Input parity bits
PO	log <sub>2</sub> (WIDTH)	output	Opt.	Parity bits
WPE	1	output	Opt.	Write parity error flag
RPE	1	output	Opt.	Read parity error flag

a. LEVEL is always 8 bits. That means for values of DEPTH greater than 256 not all values will be possible, e.g. for DEPTH =512 LEVEL can have the values 2, 4, ... , 512.

Table 15-9. Parameter Description

Parameter	Value	Function
WIDTH	width	Word length of DI and DO
DEPTH	depth	Number of RAM words
RDA	async transparent pipelined	Read Data Access
WRA	async sync	Write Data Access
OPT	speed area	Optimization
PARITY	checkeven checkodd geneven genodd none	Parity check or parity generation

Table 15-10. Implementation Parameters

Parameter	Value	Description
LPMTYPE	LPM_FIFO_DQ	Generic FIFO category
LPM_HINT	FIFO_DYN	FIFO with dynamic trigger level
LPM_HINT	FIFO_STATIC	FIFO with static trigger level

*Table 15-11. Parameter Rules for FIFO with static trigger level*

<b>Parameter Rules</b>
LEVEL <= DEPTH
If DEPTH > 256 not all values for LEVEL will be available (automatic value correction)

## **Timing Waveforms**

Please refer to the timing waveforms presented in:

- *ProASIC A500K Family Datasheet*



# FIFO Using Distributed Memory for ProASIC

## Features

- Parameterized word length and depth
- Asynchronous FIFO
- Asynchronous, or synchronous write
- Rising edge triggered or level sensitive
- Supported netlist formats:  
VHDL and Verilog

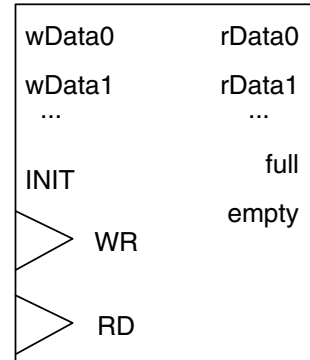

## Family support

500K, PA

## Description

Distributed memory can be generated as a two port asynchronous register file or as an asynchronous FIFO. Distributed memories are made up of the logic tiles of the device. These memory files are netlists consisting of logic tiles and do not use to embedded memory cells.

Please refer to “Memory in ProASIC” on page 180 for more detailed descriptions of ProASIC's Distributed Memories.

*Table 15-12. Port Description*

Port Name	Size	Type	Req/Opt?	Function
wData<i>	1	Input	Req.	Input (Write) Data (i = 0 .. WIDTH-1)
INIT	1	Input	Req.	FIFO initialization
WR	1	Input	Req.	Write Clock/Pulse (rising edge triggered or level sensitive)

Table 15-12. Port Description (Continued)

Port Name	Size	Type	Req/Opt?	Function
RD	1	Input	Req.	Read Clock/Pulse (rising edge triggered or level sensitive)
rData<i>	1	Output	Req.	Output (Read) Data (i = 0 .. WIDTH-1)
full	1	Output	Req.	Full Flag
empty	1	Output	Req.	Empty Flag

Table 15-13. Parameter Description

Parameter	Value	Function
WIDTH	See "Parameter Rules"	Word length input/output data
DEPTH	2..64	Number of words
TRIGGER	<b>edge</b> , level	Select between rising edge triggered and level sensitive write clock

Table 15-14. Implementation Parameters

Parameter	Value	Description
LPMTYPE	LPM_DIST_FIFO	Generic distributed FIFO category
LPM_HINT	FIFO_DISTH<#>	Horizontal Orientation # represents the part number and can be 050, 130, 180, 270 for 500K 150, 300, 450, 600, 750, 1000 for PA
	FIFO_DISTV<#>	Vertical Orientation

Table 15-15. Parameter Rules

Device	Orientation	Parameter Rules
A500K050	Horizontal	WIDTH = 2..62, DEPTH = 2..36
	Vertical	WIDTH = 2..94, DEPTH = 2..23
A500K130	Horizontal	WIDTH = 2..78, DEPTH = 2..62
	Vertical	WIDTH = 2..158, DEPTH = 2..29
A500K180	Horizontal	WIDTH = 2..94, DEPTH = 2..74
	Vertical	WIDTH = 2..190, DEPTH = 2..36
A500K270	Horizontal	WIDTH = 2..118, DEPTH = 2..80
	Vertical	WIDTH = 2..222, DEPTH = 2..45
APA150	Horizontal	WIDTH = 2..46, DEPTH = 2..49
	Vertical	WIDTH = 2..126, DEPTH = 2..16
APA300	Horizontal	WIDTH = 2..62, DEPTH = 2..49
	Vertical	WIDTH = 2..126, DEPTH = 2..23
APA450	Horizontal	WIDTH = 2..62, DEPTH = 2..74
	Vertical	WIDTH = 2..190, DEPTH = 2..23
APA600	Horizontal	WIDTH = 2..94, DEPTH = 2..80
	Vertical	WIDTH = 2..222, DEPTH = 2..36
APA750	Horizontal	WIDTH = 2..126, DEPTH = 2..80
	Vertical	WIDTH = 2..254, DEPTH = 2..49
APA1000	Horizontal	WIDTH = 2..158, DEPTH = 2..80
	Vertical	WIDTH = 2..350, DEPTH = 2..62

**Timing Waveforms**

Please refer to the timing waveforms presented in “Memory in ProASIC” on page 180 for more information.

---

## Memory in ProASIC

This appendix describes how to instantiate the memories generated by ACTgen into the design source code, simulate and synthesize the design, and import the netlist into Designer. It includes a description of ProASIC dedicated memory blocks and all their possible configurations.

### Embedded Memory

ProASIC devices contain dedicated embedded memory blocks and standard logic cells called tiles. Each block can be configured to one of 24 functions as shown in Table A-1 on page 181. Each memory block is 256 words deep and 9 bits wide, for a total of 2304 bits of memory per basic memory block. Every memory block may be configured independently as a two-port SRAM or a FIFO.

There are separate and independent read and write ports allowing simultaneous ports access. The ports can be synchronous or asynchronous. This allows the option of using an asynchronous write and a synchronous read port. Synchronous output ports can be configured to either act like a transparent synchronous port or like a pipelined synchronous port. Additionally in all modes, a parity bit (9th bit) can be checked or generated within the memory. Parity check can be performed while writing and reading data without using additional logic. The result of these checks is returned by two independent signals “WPE” and “RPE” (Write Parity Error and Read Parity Error). Parity can also be generated while reading data.

### Embedded Memory Configurations

The ability to generate additional status signals besides the standard “EMPTY” and “FULL” signals is also built into the FIFOs. By providing a level signal, the circuit also generates signals that indicate whether the FIFO is filled less, filled equally, and filled higher than the specified level. For a description of what functions each FIFO has in each configuration see the Actel *Macro Library Guide*. There are 24 different

memory configurations that ACTgen can generate. Table A-1 lists those configurations. .

*Table A-1. Embedded Memory Block Configurations*

<b>Type</b>	<b>Write Access</b>	<b>Read Access</b>	<b>Parity</b>	<b>Library Cell Name</b>
RAM	Asynchronous	Asynchronous	Checked	RAM256x9AA
RAM	Asynchronous	Asynchronous	Generated	RAM256x9AAP
RAM	Asynchronous	Synchronous Transparent	Checked	RAM256x9AST
RAM	Asynchronous	Synchronous Transparent	Generated	RAM256x9ASTP
RAM	Asynchronous	Synchronous Pipelined	Checked	RAM256x9ASR
RAM	Asynchronous	Synchronous Pipelined	Generated	RAM256x9ASRP
RAM	Synchronous	Asynchronous	Checked	RAM256x9SA
RAM	Synchronous	Asynchronous	Generated	RAM256x9SAP
RAM	Synchronous	Synchronous Transparent	Checked	RAM256x9SST
RAM	Synchronous	Synchronous Transparent	Generated	RAM256x9SSTP
RAM	Synchronous	Synchronous Pipelined	Checked	RAM256x9SSR
RAM	Synchronous	Synchronous Pipelined	Generated	RAM256x9SSRP
FIFO	Asynchronous	Asynchronous	Checked	FIFO256x9AA
FIFO	Asynchronous	Asynchronous	Generated	FIFO256x9AAP
FIFO	Asynchronous	Synchronous Transparent	Checked	FIFO256x9AST
FIFO	Asynchronous	Synchronous Transparent	Generated	FIFO256x9ASTP
FIFO	Asynchronous	Synchronous Pipelined	Checked	FIFO256x9ASR
FIFO	Asynchronous	Synchronous Pipelined	Generated	FIFO256x9ASRP
FIFO	Synchronous	Asynchronous	Checked	FIFO256x9SA
FIFO	Synchronous	Asynchronous	Generated	FIFO256x9SAP
FIFO	Synchronous	Synchronous Transparent	Checked	FIFO256x9SST
FIFO	Synchronous	Synchronous Transparent	Generated	FIFO256x9SSTP
FIFO	Synchronous	Synchronous Pipelined	Checked	FIFO256x9SSR
FIFO	Synchronous	Synchronous Pipelined	Generated	FIFO256x9SSRP

### Naming Conventions

The HDL models for each of the 24 possible configurations are included in the ProASIC simulation and synthesis library. The function and timing of each model is described in detail in the Actel *Macro Library Guide* and the *ProASIC 500K Family Datasheet*. The modules are named according to the following convention:

```
<MEM-TYPE><256x9><WRITE-ACCESS><READ-ACCESS><PARITY>
```

```
<MEM-TYPE>      := RAM or FIFO;
<WRITE-ACCESS> := A, S;
    A           := asynchronous;
    S           := synchronous;
<READ-ACCESS>  := A, ST, SR;
    A           := asynchronous;
    ST          := synchronous transparent;
    SR          := synchronous registered;
<PARITY>       := P or nothing;
    P           := parity will be generated;
    nothing     := parity will be checked;
```

For example, the name of a FIFO with an asynchronous write and a synchronous transparent read mode with parity check is “FIFO256x9AST.” Or a synchronous registered RAM with parity bit generation would be named “RAM256x9SSRP.”

### Integrating Memories into a Design

This section provides examples of how to integrate a Verilog or VHDL memory netlist into a design. Once ACTgen has generated the memories you must incorporate the netlist into your design before simulation and synthesis. ACTgen generates a netlist file with the .v, .vhd or .edn extension and a constraint file with the .gcf extension, which is no longer needed to perform automatic place-and-route of the memories.

**Example Verilog RAM 512x32**

The following is a Verilog netlist generated by ACTgen for a 512x32 bit RAM:

```
'timescale 1ns/10ps
// Name = ram512x32
// type = RAM
// width = 32
// depth = 512
// part family = A500K
// output type = asynchronous
// optimization = speed
// input type = synchronous
// parity control = ignore
// Write = active low
// Read = active low
// Write clock = posedge

module ram512x32(DO, WCLOCK, DI, WRB, RDB, WADDR, RADDR);
    output [31:0] DO;
    input WCLOCK;
    input [31:0] DI;
    input WRB;
    input RDB;
    input [8:0] WADDR;
    input [8:0] RADDR;

    GND U1(.Y(VSS));
    RAM256x9SA M0(.WCLKS(WCLOCK), .DO8(n27), .DO7(n24), .DO6(n21),
    .DO5(n18),
    .....
    //memory blocks instantiation

endmodule
```

The following is an example of how to instantiate a ram512x32 module into a design:

```
ram512x32 MY_RAM_INST(.DO(data_out), .WCLOCK(clk),
    .DI(data_in), .WRB(wrb), .RDB(rdb), .WADDR(write_add),
    .RADDR(read_add));
```

After instantiating the memory into the Verilog source code, the next step is to simulate and synthesize the design. Before synthesizing the design, make sure that the “dont\_touch” attribute is set on all memories generated by ACTgen.

Refer to the the documentation included with your synthesis tool for additional information on how to apply a “dont\_touch” attribute on a memory block.

### **VHDL RAM Example**

The following is a VHDL example of the previously generated memory:

```
-- Name = ram512x32
-- type = RAM
-- width = 32
-- depth = 512
-- part family = A500K
-- output type = asynchronous
-- optimization = speed
-- input type = synchronous
-- parity control = ignore
-- Write = active low
-- Read = active low
-- Write clock = posedge

entity ram512x32 is
port(DO      : out std_logic_vector (31 downto 0);
     WCLOCK  : in  std_logic;
     DI      : in  std_logic_vector (31 downto 0);
     WRB     : in  std_logic;
     RDB     : in  std_logic;
     WADDR   : in  std_logic_vector (8  downto 0);
     RADDR   : in  std_logic_vector (8  downto 0));

end ram512x32;
```

The entity describes the interface of the module that must be instantiated into the VHDL design source code. Besides the actual connection of the interface, VHDL requires an additional declaration of the sub-module in the architecture. The following is an example of an architecture declaration including the declaration of the memory as a component:

```
architecture STRUCT_ram512x32 of ram512x32 is
component PWR
    port(Y : out std_logic);
end component;

component GND
    port(Y : out std_logic);
end component;
```



```

component RAM256x9SA
  port(WCLKS : in std_logic;
        DO8 : out std_logic;
        DO7 : out std_logic;
        .....
  );
end component;
.....
begin
  .....
  M0 : RAM256x9SA port map(WCLKS => WLOCK, DO8 => n27, DO7
=> n24,
  .....
end STRUCT_ram512x32;

```

### Importing the Netlist into Designer

After synthesis, a design is translated into either a Verilog, VHDL, or an EDIF netlist. The netlist includes all logic blocks as well as the memories. To import the netlist file(s) into Designer, refer to the *Designer User's Guide*.

Table A-2. Possible RAM Locations for the A500K Family

Part	possible RAM locations	formula
A500K050	(1,57), (17, 57), ..., (81, 57)	$x = 16*n+1; n = \{0,1,2,3,4,5\}; y = 57;$
A500K130	(1,81), (17, 81), ..., (145,81) (1,89), (17, 89), ..., (145,89)	$x = 16*n+1; n = \{0,1,2,3,4,5,6,7,8,9\}$ $y = \{81, 89\}$
A500K180	(1,97), (17,97), ..., (177, 97) (1,105), (17,105), ..., (177, 105)	$x = 16*n+1; n = \{0,1,2,3,4,5,6,7,8,9,10,11\}$ $y = \{97, 105\}$
A500K270	(1,121), (17,121), ..., (209,121) (1,129), (17,129), ..., (209,129)	$x = 16*n+1; n = \{0,1,2,3,4,5,6,7,8,9,10,11,12,13\}$ $y = \{121, 129\}$

Designer automatically places the memories serially. If you want to place memories in any other way, use manual memory placement, as described in the next section.

**Note:** If you use the previous memory modules in a synthesis flow, make sure that you set “dont\_touch” attributes on the modules generated by

ACTgen. Otherwise, the names of these modules may be changed and Designer cannot find the memory modules to be placed in the netlist.

### **Manual Memory Placement**

For manual placement, a .gcf constraints file must be created. The following is an example of a manually created placement file for a A500K130 device.

```
set_location (1,81) <hier_instance_name>/M0;  
set_location (1,89) <hier_instance_name>/M1;  
set_location (33,89) <hier_instance_name>/M2;  
set_location (33,81) <hier_instance_name>/M3;
```

The (x,y) coordinates are device dependent. If wrong coordinates are entered, Designer reports about wrong coordinates and displays a list of valid coordinates for the selected device. Refer to Table A-2 on page 185 for valid coordinates for each device.

## **Distributed Memory**

This section describes the distributed memory architecture and how to use ACTgen to create distributed memories for ProASIC device.

### **Distributed Memory Architecture**

Distributed memory can be generated as a two port asynchronous register file or as an asynchronous FIFO. Distributed memories are made up of the logic tiles of the device. These memory files are netlists consisting of logic tiles and do not use embedded memory cells.

#### **The Register File**

The register file has independent read and write ports. The read port is asynchronous so the read data is not clocked and is available a short time after the read address changes. The write port is also asynchronous and data is written on the active edge of WR. The write operation can be either level sensitive or edge-sensitive. The schematic of a 2x2 memory is shown in Figure A-1 on page 187. The schematic is marked to show the words (vertical slices), the bits (horizontal slices) and the decoders (one per word). The register file

memory requires 1 column per word and 2 rows per bit plus from 1 to 3 rows for the necessary decoders.

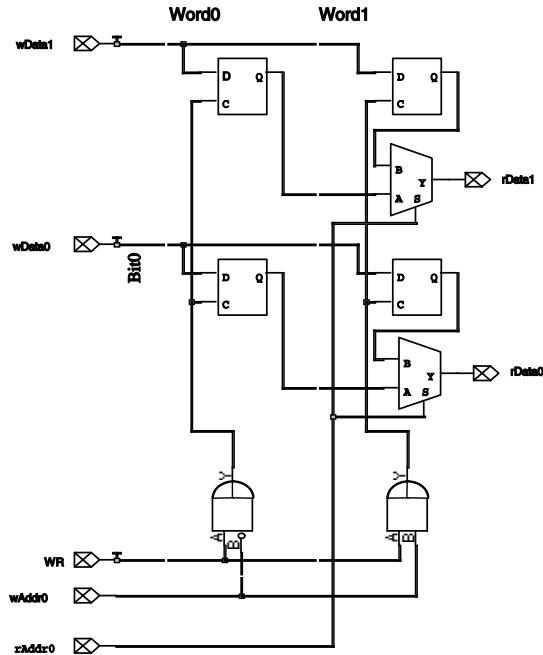

Figure A-1. 2x2 Register File Schematic

### Distributed FIFO

A Distributed FIFO also has independent read and write ports. However, it has no address ports. Instead, the FIFO keeps track of the addresses internally. The FIFO is organized with words in columns and data bits in rows. The top row consists of the write addressing circuitry and the “full” detection circuitry. The second row consists of the read addressing circuitry and the “empty” detection circuitry. The FIFO requires two columns per word plus an overhead for decoders and flag generation that is a minimum of three columns. The FIFO

also requires one row per bit plus an overhead of two rows. Figure A-2 shows the schematic of a 2x2 FIFO.

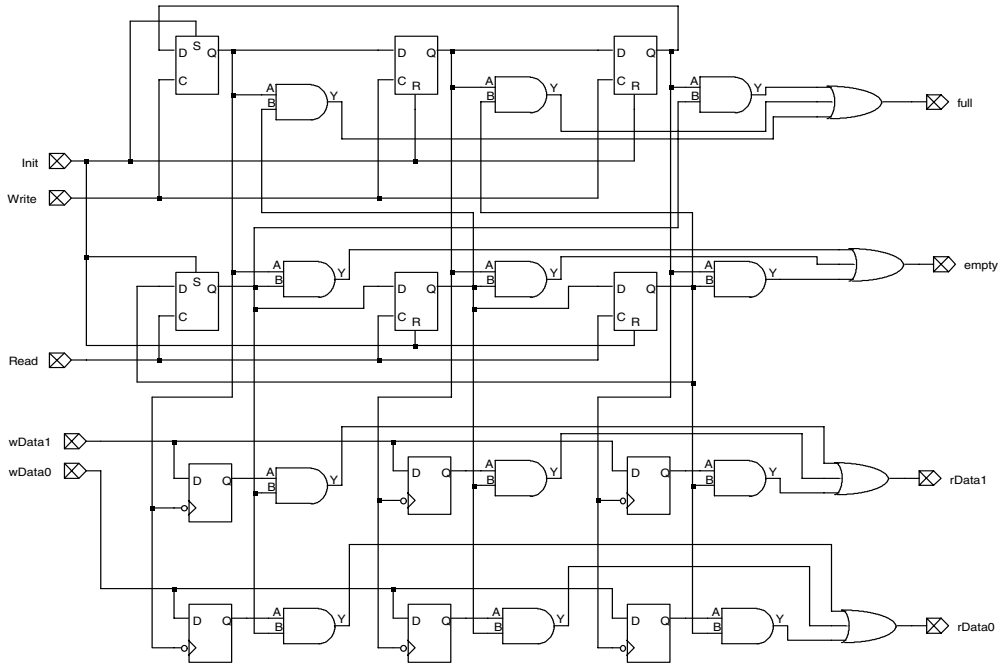

Figure A-2. 2x2 FIFO Schematic

### Determining Tile Usage

ProASIC parts tend to have more tiles horizontally. The choice of orientation affects the allowable size of the memory. A horizontal memory allows the maximum possible number of words. A vertical memory allows the maximum number of bits per word. ACTgen can create register files of up to 64 words on any possible ProASIC device. Distributed memories are created using logic tiles and are generally slower and larger compared to embedded RAM. Actel recommends that larger memories be implemented with embedded memory.

The maximum distributed FIFO sizes in any ProASIC device is 80 words. The maximum RAM and FIFO sizes are shown in Table A-3.

*Table A-3. Maximum RAM and FIFO Dimensions*

Device	Vertical		Horizontal	
	Words	Width	Words	Width
A500K050	64 (23) <sup>1</sup>	46 (94)	64 (36)	30 (62)
A500K130	64 (29)	78 (158)	64 (62)	38 (78)
A500K180	64 (36)	95 (192)	64 (75)	46 (94)
A500K270	64 (45)	110 (222)	64 (80)	58 (118)
APA	64 (45)	110 (222)	64 (80)	58 (118)

1. Numbers in parentheses are for FIFOs.

The orientation of the register file affects how it is placed. Horizontal register files are placed with words in columns and bits in rows as shown in Figure A-3.

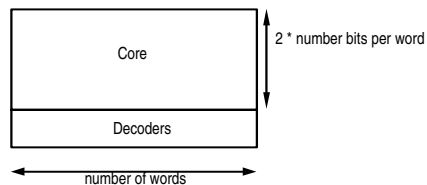

*Figure A-3. Horizontal Memory*

Vertical memories are placed with bits in columns and words in rows as shown in Figure A-4.

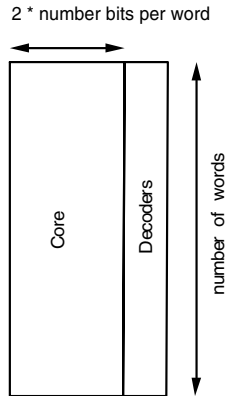

Figure A-4. Vertical Memory

The decoder sizes are given in table Table A-4.

Table A-4. Decoder Sizes

Number of Words	Decoder Size
2 ~ 4	1
5 ~ 8	2
9 ~ 64	3

### Calculating Logic Usage

The following section presents how to calculate logic usage for Memory area, and a vertical and a horizontal memory.

#### Memory Area

The following is an example of how to calculate memory area:

$$\text{Memory Area} = \text{Number of Words} \\ (2 * \text{Number of bits} + \text{decoder size})$$

### *Vertical Orientation*

The following is an example logic usage calculation for a 16x32 RAM:

$$\begin{aligned} \text{Width in tiles} &= 2 * \text{number-of-Bits-per-word} + \text{decoder size} \\ &= 2 * 32 + 3 = 67 \end{aligned}$$

$$\text{Height in tiles} = \text{number-of-words} = 16$$

### *Horizontal Orientation*

The following is an example logic usage calculation for a 16x32 RAM:

$$\text{Tiles in Width} = \text{Number-of-Words} = 16$$

$$\begin{aligned} \text{Tiles in Height} &= 2 * \text{number-of-bits-per-word} + \text{decoder size} \\ &= 2 * 32 + 3 = 67 \end{aligned}$$

ACTgen displays the legal coordinates to place the memory if the macro is not rotated or flipped. The horizontal could be placed between the coordinates (1,1) and (145, 15) assuming the A500K130 device was selected.

### *Distributed Memory Placement*

To achieve the best timing and efficient placement, use the placement constraints file generated by ACTgen. For more information on constraint statements, refer to the *Getting Started User's Guide*. To utilize this file, use the “set\_location” constraint statement for macros. For example:

```
set_location (x,y) <mem_hier_name> <macro_name>;
```

### *Distributed Memory Timing*

Memory timing values are dependent on the memory size and the routing to and from the memory. Since the memories are implemented as ProASIC primitives, users can determine the timing characteristics of the circuit by performing a back annotated timing analysis. In fact, to the timing analyzer, the distributed memory looks like any other part of the circuit and requires no special treatment. “Timing for Distributed Memories” on page 192 explains the critical timing paths in each memory, and why these paths are critical.

## Distributed Memory Generation and Instantiation

Consider the following hierarchical design, which instantiates a 16x32 memory as shown in Figure A-5.

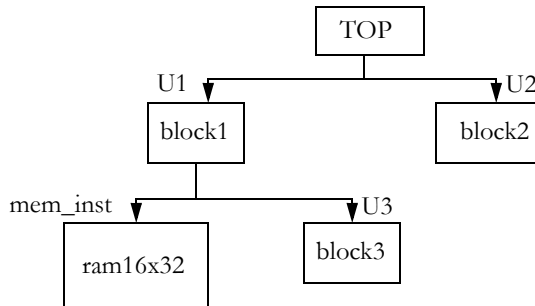

Figure A-5. Design Example

### Simulation and Synthesis

After instantiating a memory into the design, simulate and synthesize it. Memory models are included into the simulation and synthesis libraries. Refer to the documentation included with your simulation and synthesis tools for additional information. During synthesis make sure that the “dont\_touch” attribute is set on all memories generated by ACTgen.

### Place-and-Route

After synthesis, a netlist is written out that contains the embedded memories and the logic of a design. Designer treats the memory as a macro and places it in a rectangle with the bottom-left corner on tile coordinate (10,10). Memory can be moved on the die by changing this coordinate.

**Note:** Distributed memory contains very high fanout nets so, if you do not use the above placement constraints, memory timing will be sub-optimal or the design may not route.

## Timing for Distributed Memories

The following chapter describes the timing parameters for the level sensitive register file, and edge-triggered register file. It also includes information about edge-triggered FIFOs.



## Level-sensitive Register File

The level-sensitive register file has three main timing parameters.

- $T_{acc}$  - time from stable read-address to output data valid
- $T_{setup\_data}$  - time from stable write-data to falling edge of WR
- $T_{setup\_addr}$  - time from stable write-address to rising clock edge

Figure A-6 shows the timing of these parameters:

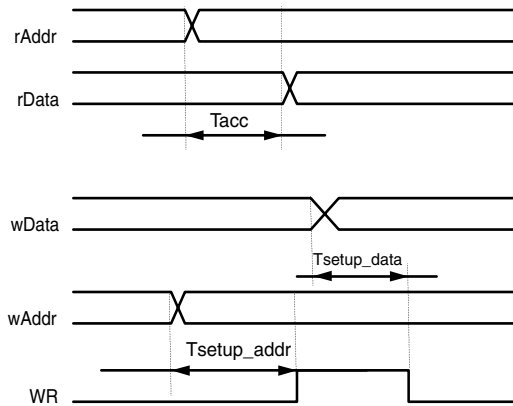

*Figure A-6. Level-sensitive Mode Timing Diagram*

Failure to meet these timing values will have the following results:

- $T_{acc}$  - read data might be from previous address
- $T_{setup\_data}$  - data may not be written into the memory
- $T_{setup\_addr}$  - data may be written into some other address as well as the intended address

## Edge-triggered Register File

The edge-triggered register file has three main timing parameters:

- $T_{acc}$  - time from stable read-address to output data valid
- $T_{setup\_data}$  - time from stable write-data to rising WR edge
- $T_{setup\_addr}$  - time from stable write-address to rising WR edge

Figure A-7 shows the relationships of the signals.

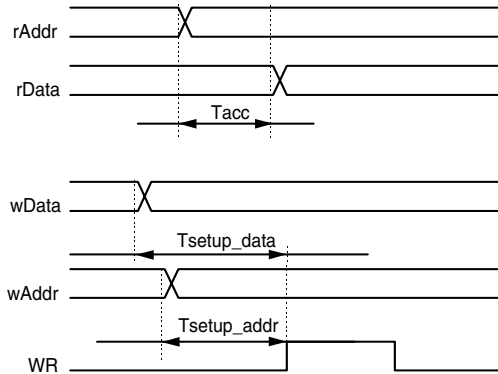

Figure A-7. Edge-triggered Mode Timing Diagram

Failure to meet these timing values will have the following results:

- $T_{acc}$  - read data might be from previous address
- $T_{setup\_data}$  - data may not be written into the memory
- $T_{setup\_addr}$  - data may be written into some other address

The main advantage of the edge-triggered memory is that the write timing is sensitive only to the rising edge of the **WR**, not both the rising and falling edges.

### Edge-triggered FIFO

The edge-triggered FIFO captures data on the rising edge of the “**WR**” signal, and the read pointers advance on the rising edge of the “**RD**” signal. Before using the FIFO, it must be initialized by pulsing the “**INIT**” signal high. Immediately after initialization, the “empty” signal is true and the “full” signal false. Data applied on the “**wDataX**” signals are captured when the “**WR**” signal transitions from 0 to 1. Simultaneously, the “empty” signal will become false to indicate that there is valid data on “**rDataX**.” Further transitions from 0 to 1 on “**WR**” captures more data into the FIFO until such time as “full” becomes true. At this point, the FIFO is full, and no more data should be entered into it.

After the FIFO is initialized, the output data remains invalid until the first read operation is performed. With every rising edge of the read pulse, the FIFO

generates the next word written into it on the output data bus until all the words written into it are read out. At this point the “empty” signal goes high. Further read operations produce no change to the data output as it remains fixed at the last word written into the FIFO.

Figure A-8 shows an example of an Edge triggered FIFO. It has the following main timing:

- Tacc - Access from RD rising edge to output data valid
- Tacc - Access from RD rising edge to output data valid
- Tsu - Setup time from stable write-data to rising WR edge
- Thold - Hold time for write-data from rising WR edge

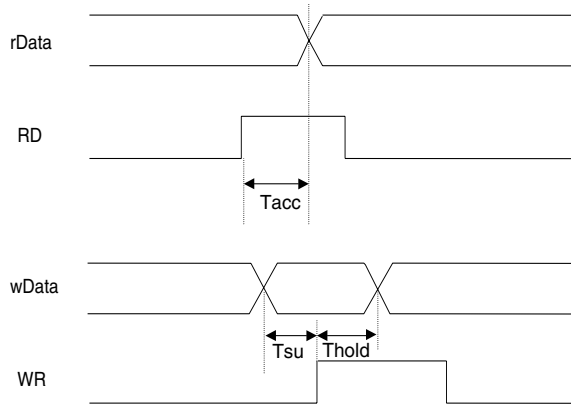

Figure A-8. Edge-triggered FIFO Timing Diagram

### Level Sensitive FIFO

The level sensitive FIFO has the same timing as the edge-triggered FIFO. The only difference is that the data input is latched at the falling edge of the write pulse.

## Using Multiple Memories in a Design

This chapter describes how to use multiple memories in a design. If a design includes several memories with different sizes and access modes, Actel recommends generating them all in one session of ACTgen. The embedded memories are automatically generated and are accompanied by placement directives.

## Multiple Memory Generation and Integration

ProASIC devices contain dedicated embedded memory blocks that can be configured as RAM or FIFO. Multiple memory blocks can be combined together to create deep and wide memories. ACTgen does this by combining multiple memory blocks as required. The tool generates netlists for these blocks. Netlist instantiates memory leaf cells. Consider the following design shown in Figure A-9.

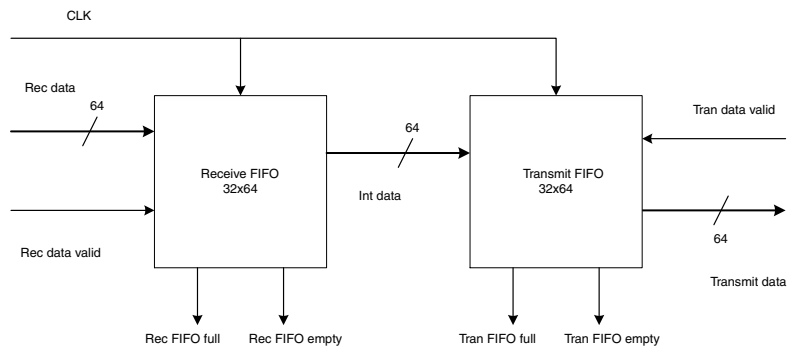

Figure A-9. Sample Design

In this design, there is a receive FIFO and transmit FIFO. Read and Write ports are synchronous. Each FIFO is 32 words deep and 64 bits wide. Also, both FIFOs are identical. Only one FIFO needs to be created with ACTgen, and it must be instantiated twice into the design.

Once the FIFO is generated with ACTgen, it must be instantiated into the design. The following is an example of the RTL after instantiation:

```

module top(tran_data, rec_data, rec_data_valid,
           tran_data_valid, clk, reset, rec_fifo_full,
           rec_fifo_empty, tran_fifo_full, tran_fifo_empty);
  // this is top level module
  input rec_data_valid, clk, reset, tran_data_valid;
  output [63:0] tran_data;
  output rec_fifo_full, rec_fifo_empty, tran_fifo_full,
         tran_fifo_empty;
  input [63:0] rec_data;
  wire [63:0] data_int;
  /* Receiver FIFO instantiation */
  sync_fifo rec_FI(.data_in(rec_data), .data_out(data_int),
                  .wr(rec_data_valid), .rd(1'b0),
                  .empty(rec_fifo_empty), .full(rec_fifo_full),

```

```
                .reset(reset), .clk(clk));
/* transmit FIFO instantiation */
sync_fifo tran_FI(.data_in(data_int),
                 .data_out (tran_fifo_full)
                 .wr(1'b0), .rd(tran_data_valid),
                 .empty(tran_fifo_empty), .full(tran_fifo_full),
                 .reset(reset), .clk(clk));
/* other RTL of the design and other blocks */

endmodule

module sync_fifo (data_in, data_out, wr, rd, empty, full,
                 reset, clk);
input[63:0] data_in;
output[63:0] data_out;
input wr, rd, clk, reset;
output empty, full;
/* Instantiation of FIFO generated from ACTgen */fifo32x64
F1(.DO(data_out), .RCLOCK(clk), .WCLOCK(clk),
   .DI(data_in), .WRB(wr), .RDB(rd), .RESET(reset),
   .FULL(full), .EMPTY(empty), .EQTH(), .GEQTH());

endmodule
```

### ***Simulate and Synthesize***

Now the design can be simulated and synthesized. The following is an example of a Verilog-XL simulation command:

```
verilog test_sim.v top.v fifo32x64.v -v
$AMHOME/etc/deskits/verilog/lib/A500K.v
```

The following is a typical Design Compiler script for synthesis of a design including memory blocks:

```
read -format verilog fifo32x64
set_dont_touch find(design, "fifo32x64") /* memories must be
dont_touch during synthesis */
read -format verilog top.v
create_clock -period 20 clk /* add timing constraints */
set_wire_load A500K
set_operating_conditions WORST
compile
set_port_is_pad "" /* use set_pad_type to to use a particular
type of pad */
insert_pads
write -format verilog -hierarchy -output top_str.v /* write
out netlist with hierarchy */
quit
```

### ***Memory Placement***

The netlist “top\_str.v” contains both FIFO instantiations and can be used for post synthesis gate level simulation. After synthesis, you can place and route the design. In this example, each FIFO uses 8 memory blocks. Designer automatically attempts to place each FIFO in a line. The resulting placement on an A500K130 device, which has 20 memory slots, is shown in Figure A-10 on page 200. For information about the ChipEdit tool, refer to the *ChipEdit User's Guide*.

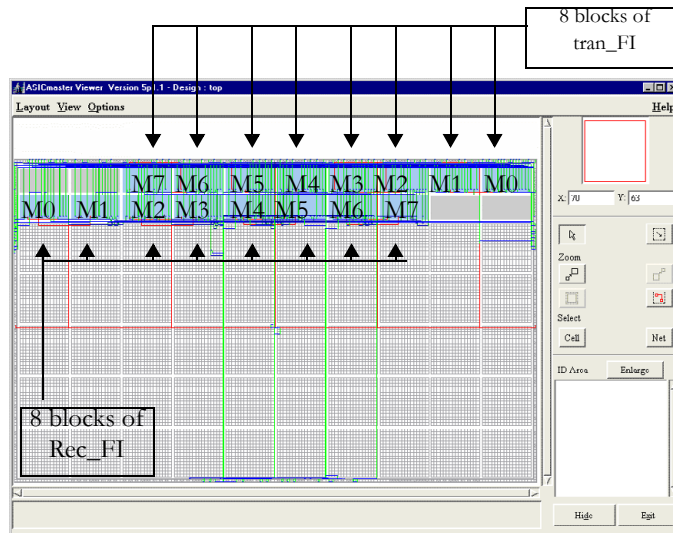

Figure A-10. Sample Memory Placement (Screen May Vary Slightly)

During placement Designer attempts to keep one memory entity in one group. In the example shown in Figure A-10, it placed the “Rec\_FI/F1/M0” in the first memory slot on the left side of the lower row, and “rec\_FI/F1/M1” in next slot and so on. Only ten slots were available in one row and therefore, the placement of “tran\_FI” started from the upper row. If each memory block had used four blocks, both memory blocks would be placed one after another in the lower row.

### Manual Placement of Multiple Memories

A memory placement file must be created to manually place memories. For example, to place the “rec\_FI” from the previous example on the left side using both rows and the “tran\_FI” on right side in both rows, the following placement file would be used:

```

set_location (1,81) rec_FI/F1/M0;
set_location (1,89) rec_FI/F1/M1;
set_location (17,89) rec_FI/F1/M2;
set_location (17,81) rec_FI/F1/M3;
set_location (33,81) rec_FI/F1/M4;
    
```



```

set_location (33,89) rec_FI/F1/M5;
set_location (49,89) rec_FI/F1/M6;
set_location (49,81) rec_FI/F1/M7;

set_location (145,81) tran_FI/F1/M0;
set_location (145,89) tran_FI/F1/M1;
set_location (129,89) tran_FI/F1/M2;
set_location (129,81) tran_FI/F1/M3;
set_location (113,81) tran_FI/F1/M4;
set_location (113,89) tran_FI/F1/M5;
set_location (97,89) tran_FI/F1/M6;
set_location (97,81) tran_FI/F1/M7;

```

This constraints file should be read into Designer and would result in the placement shown in Figure A-11 on an A500K130 device.

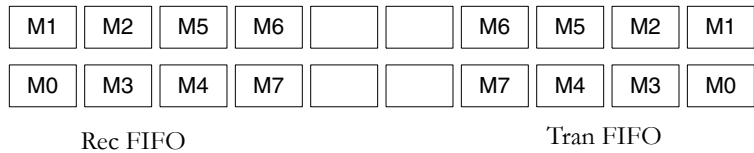

*Figure A-11. Sample FIFO Placement*

Designer determines the placement for each memory and keeps each memory entity together. To change default placement, you can create constraints manually for memory placement as described in Chapter 1.

**Glue Logic for Wider or Deeper Memories**

If very deep or very wide memories are created, ACTgen combines together multiple basic blocks and uses embedded logic. Two lists quantifying glue logic are shown in Table A-5 and Table A-6 on page 202 .

These tables cover extreme cases of depth or width for RAMs and FIFOs for the A500K130 device, which offers 20 memory blocks and 12800 logic tiles.

Table A-5. RAM

RAM	Parity	Memory Blocks Used	Logic Tile Used	Comment
Depth 5120 Width 8	Check Even	20	259	All 20 blocks used in depth
Depth 256 Width 160	Check Even	20	22	All 20 blocks used in width

Table A-6. FIFO

FIFO	Parity	Memory Blocks Used	Logic Tile Used	Comment
Depth 5120 Width 8	Check Even	20	592	All 20 blocks used in depth
Depth 256 Width 160	Check Even	20	62	All 20 blocks used in width

For FIFOs, ACTgen creates placement directives for glue logic. If placement information from ACTgen is used, glue logic placement is more efficient.

### Programmable Flags in FIFOs

ProASIC devices provide programmable flags for FIFOs. The threshold for these flags can be set in ACTgen in the main menu, shown in Figure 1-1 on

page 12. It is on the bottom right corner in the FIFO Trigger Level box. You can specify whether the flag is static or dynamic. If dynamic is selected, ACTgen will create a FIFO with a LEVEL input bus on the memory interface. You can apply values in the range of 0 to 255 to this bus to change its threshold dynamically.

The overall trigger level is a multiple “d,” which is the number of used basic memory blocks in depth (each 256 words). The increment between each overall trigger level is equal to “d.” For example, a memory that is 512 words deep is built up of two basic memory block in depth (512/256). The highest almost full trigger level should be assigned, which is 510 ( $512-d = 512-2$ ) The corresponding dynamic trigger LEVEL is 255 ( $510/n = 510/2$ ).

If the threshold is not changing, you can select the static option and specify the threshold value. In this case, ACTgen will hardwire threshold to the specified value. A detailed timing of these flags can be found in the *ProASIC 500k Family Datasheet*.

Trigger level is also called threshold. Consequently, equal threshold (EQTH) and greater equal threshold (GEQTH) are the names of the trigger flags.



---

## *Product Support*

Actel backs its products with various support services including Customer Service, a Customer Technical Support Center, a web site, an FTP site, electronic mail, and worldwide sales offices. This appendix contains information about contacting Actel and using these support services.

### *Actel U.S. Toll-Free Line*

Use the Actel toll-free line to contact Actel for sales information, technical support, requests for literature, Customer Service, investor information, and using the Action Facts service.

The Actel toll-free line is (888) 99-ACTEL.

### *Customer Service*

Contact Customer Service for non-technical product support, such as product pricing, product upgrades, update information, order status, and authorization.

From Northeast and North Central U.S.A., call (408) 522-4480.

From Southeast and Southwest U.S.A., call (408) 522-4480.

From South Central U.S.A., call (408) 522-4434.

From Northwest U.S.A., call (408) 522-4434.

From Canada, call (408) 522-4480.

From Europe, call (408) 522-4252 or +44 (0) 1276 401500.

From Japan, call (408) 522-4743.

From the rest of the world, call (408) 522-4743.

Fax, from anywhere in the world (408) 522-8044.

### *Actel Customer Technical Support Center*

Actel staffs its Customer Technical Support Center with highly skilled engineers who can help answer your hardware, software, and design questions. The Customer Technical Support Center spends a great deal of time creating application notes and answers to FAQs. So, before you contact us, please visit our online resources. It is very likely we have already answered your questions.

## *Guru Automated Technical Support*

Guru is a web-based automated technical support system accessible through the Actel home page (<http://www.actel.com/guru/>). Guru provides answers to technical questions about Actel products. Many answers include diagrams, illustrations, and links to other resources on the Actel web site.

## *Web Site*

Actel has a World Wide Web home page where you can browse a variety of technical and non-technical information. The URL is <http://www.actel.com>.

## *Contacting the Customer Technical Support Center*

Highly skilled engineers staff the Technical Support Center from 7:00 A.M. to 6:00 P.M., Pacific Time, Monday through Friday. Several ways of contacting the Center follow:

### ***Electronic Mail***

You can communicate your technical questions to our e-mail address and receive answers back by e-mail, fax, or phone. Also, if you have design problems, you can e-mail your design files to receive assistance. We constantly monitor the e-mail account throughout the day. When sending your request to us, please be sure to include your full name, company name, and your contact information for efficient processing of your request.

The technical support e-mail address is **tech@actel.com**.

## ***Telephone***

Our Technical Support Center answers all calls. The center retrieves information, such as your name, company name, phone number and your question, and then issues a case number. The Center then forwards the information to a queue where the first available application engineer receives the data and returns your call. The phone hours are from 7:00 A.M. to 6:00 P.M., Pacific Time, Monday through Friday. The Technical Support numbers are:

***(408) 522-4460***

***(800) 262-1060***

Customers needing assistance outside the US time zones can either contact technical support via email ([tech@actel.com](mailto:tech@actel.com)) or contact a local sales office. Please see our list of [Worldwide Sales Offices](#).

## Worldwide Sales Offices

### Headquarters

Actel Corporation  
955 East Arques Avenue  
Sunnyvale, California 94086  
Toll Free: 888.99.ACTEL  
Tel: 408.739.1010  
Fax: 408.739.1540

### US Sales Offices

#### California

Bay Area  
Tel: 408.328.2200  
Fax: 408.328.2358

Irvine  
Tel: 949.727.0470  
Fax: 949.727.0476

Newbury Park  
Tel: 805.375.5769  
Fax: 805.375.5749

#### Colorado

Tel: 303.420.4335  
Fax: 303.420.4336

#### Florida

Tel: 407.977.6846  
Fax: 407.977.6847

#### Georgia

Tel: 770.277.4980  
Fax: 770.277.5896

#### Illinois

Tel: 847.259.1501  
Fax: 847.259.1575

#### Massachusetts

Tel: 978.244.3800  
Fax: 978.244.3820

#### Minnesota

Tel: 651.917.9116  
Fax: 651.917.9114

#### New Jersey

Tel: 609.517.0304

#### North Carolina

Tel: 919.654.4529  
Fax: 919.674.0055

#### Pennsylvania

Tel: 215.830.1458  
Fax: 215.706.0680

#### Texas

Tel: 972.235.8944  
Fax: 972.235.9659

### International Sales Offices

#### Canada

235 Stafford Rd. West, Suite 106  
Nepean, Ontario K2H9C1, Canada  
Tel: 613.726.7575  
Fax: 613.726.8666

#### France

361 Avenue General de Gaulle  
92147 Clamart Cedex  
Tel: +33 (0)1.40.83.11.00  
Fax: +33 (0)1.40.94.11.04

#### Germany

Lohweg 27,  
D-85375 Neufahrn  
Germany  
Tel: +49.(0)81.659.584.0  
Fax: +49.(0)81.659.584.10

#### Italy

Via dei Garbaldini 5  
20019 Settimo Milanese  
Milano, Italy  
Tel: +39 (0)2.3809.3259  
Fax: +39 (0)2.3809.3260

#### Japan

EXOS Ebisu Building 4F  
1-24-14 Ebisu Shibuya-ku  
Tokyo 150

Tel: +81 (0)3.3445.7671  
Fax: +81 (0)3.3445.7668

#### Korea

30th floor, ASEM Tower,  
159-1 Samsung-dong,  
Kangnam-ku, Seoul, Korea  
Tel: +82 (0)2.6001.3382  
Fax: +82 (0)2.6001.3030

#### United Kingdom

Maxfli Court  
Riverside Way  
Camberley, Surrey  
GU15 3YL  
United Kingdom  
Tel: +44 (0)1276.401450  
Fax: +44 (0)1276.401490